

# CR60

Optimised circular fire damper 60-90'



CE  
0749



UK  
CA













## Table of content

Declaration of performance	4
Product presentation CR60	5
Range and dimensions CR60	6
Variant CR60-L500	6
Range and dimensions CR60-L500	6
Variant CR60-1S	7
Range and dimensions CR60-1S	7
Variant CR60-1S-L500	8
Range and dimensions CR60-1S-L500	8
Evolution - kits	8
Options - at the time of order	11
Storage and handling	12
Installation	12
Installation at a minimal distance from another damper or from an adjacent supporting construction	13
Installation in rigid wall and floor	15
Installation in flexible wall (metal stud gypsum plasterboard wall)	17
Installation in flexible wall (metal stud gypsum plasterboard wall), sealing with gypsum	19
Installation in flexible wall (metal stud gypsum plasterboard wall), sealing with mortar	21
Installation in gypsum block wall	23
Installation in flexible and rigid wall, sealing with rigid rock wool boards with coating	25
Installation in rigid floor, sealing with rigid rock wool boards with coating	28
Installation in rigid wall and floor with collar for surface-mount 1s	30
Installation in flexible wall with collar for surface-mount 1s	31
Installation in shaft wall with collar for surface-mount 1s	32
Installation in shaft wall, sealing with gypsum	33
Installation in shaft wall, sealing with rigid rock wool boards with coating	34
Installation remote from the wall, sealing and insulation with rigid rock wool boards with coating	36
Installation remote from the wall, sealing with mortar and insulation with rigid rock wool boards with coating	39
Installation remote from the wall + GEOFLAM	41
Inspection of the damper	44
Operation and mechanisms	45
Electrical connection	49
Weights	51
Selection data	52
Example	52
Sample order	54
Approvals and certificates	55

## Explanation of the abbreviations and pictograms

Wn = nominal width	E.TELE = power supply magnet	Sn = free air passage
Hn = nominal height	E.ALIM = power supply motor	$\zeta$ [-] = pressure loss coefficient
Dn = nominal diameter	V = volt	Q = airflow
E = integrity	W = watt	$\Delta P$ = static pressure drop
I = thermal insulation	Auto = automatic	v = air speed in the duct
S = smoke leakage	Tele = remote controlled	Lwa = A-weighted sound power level
Pa = pascal	Pnom = nominal capacity	Lw oct = sound power level per octave midband
ve = vertical wall penetration	Pmax = maximum capacity	dB(A) = A-weighted decibel value
ho = horizontal floor penetration	GKB (type A) / GKF (type F): "GKB"	$\Delta L$ = correction factor
o -> i = meets the criteria from the outside (o) to the inside (i)	stands for standard plasterboards (type A according to EN 520) while "GKF" plasterboards offer a higher fire resistance for a similar plate thickness (type F according to EN 520)	
i <-> o = fire side not important	Cal-Sil = calcium silicate	
V AC = Volt alternating current	OP = option (delivered with the product)	
V DC = Volt direct current	KIT = kit (delivered separately for repair or upgrade)	
	PG = connection flange to the duct	

	air-tightness class C according to EN1751		higher net building volume through compact size
	optimal acoustic performance		optimal free air passage and minimal pressure loss
	minimal distance allowed		suitable for built-in installation
	suitable for surface-mount		suitable for installation remote from the wall
	sealing with fire resistant stone wool boards allowed, also for asymmetric opening		fast installation

## DECLARATION OF PERFORMANCE

CE\_DoP\_Rf-t\_C9\_EN = K-03/2023

1. Unique identification code of the product-type:	CR60
2. Intended use(s):	Circular fire damper to be used in conjunction with partitions to maintain fire compartments in heating, ventilating and air conditioning installations.
3. Manufacturer:	Rf-Technologies NV, Lange Ambachtstraat 40, B-9860 Oosterzele
4. System(s) of AVCP:	System 1
5. Harmonised standard / European Assessment Document; notified body / European Technical Assessment, technical Assessment Body, notified body, certificate of constancy of performance:	EN 15650:2010, BCCA with identification number 0749; BCCA-0749-CPR-BC1-606-0464-1565002-2517 2822-UMKA-CPR-0055

(Fire resistance according to EN 1366-2 and classifications according to EN 13501-3)

Essential characteristics	Performance		Harmonised standard EN 15650:2010
	Wall type	Classification	
Range Ø 100-315 mm	Rigid wall	1 EI 90 (V, I ⊕ ⊕) S - (500 Pa)	
	Aerated concrete ≥ 100 mm	1 EI 90 (V, I ⊕ ⊕) S - (300 Pa)	
	Mortar / Gypsum	1 EI 90 (V, I ⊕ ⊕) S - (300 Pa)	
	Stone wool + coating ≥ 140 kg/m <sup>3</sup>	1 EI 60 (V, I ⊕ ⊕) S - (300 Pa)	
	Stone wool Mulcol Multimastic FBI + coating	1 EI 60 (V, I ⊕ ⊕) S - (300 Pa)	
	Stone wool + coating ≥ 140 kg/m <sup>3</sup> 1x60 mm	2 EI 90 (V, I ⊕ ⊕) S - (300 Pa)	
	Galvanised duct + stone wool + coating ≥ 140 kg/m <sup>3</sup> 2x50 mm	2 EI 90 (V, I ⊕ ⊕) S - (300 Pa)	
	Galvanised duct + stone wool + coating ≥ 140 kg/m <sup>3</sup> 2x50 mm + mortar	2 EI 90 (V, I ⊕ ⊕) S - (300 Pa)	
	Galvanised duct + stone wool + coating ≥ 140 kg/m <sup>3</sup> 2x50 mm + mortar	2 EI 90 (V, I ⊕ ⊕) S - (300 Pa)	
	Galvanised duct + GEOTFLAM® F 45 mm + mortar	2 EI 90 (V, I ⊕ ⊕) S - (500 Pa)	
	Galvanised duct + GEOTFLAM® Light 35 mm + mortar	2 EI 90 (V, I ⊕ ⊕) S - (500 Pa)	
	Stone wool + coating ≥ 140 kg/m <sup>3</sup>	3 EI 90 (V, I ⊕ ⊕) S - (300 Pa)	
	Mortar	3 EI 90 (V, I ⊕ ⊕) S - (500 Pa)	
	Aerated concrete ≥ 100 mm	1 EI 60 (V, I ⊕ ⊕) S - (500 Pa)	
	Metal studs gypsum plasterboard Type A (EN 520) ≥ 100 mm	1 EI 60 (V, I ⊕ ⊕) S - (300 Pa)	
	Metal studs gypsum plasterboard Type A (EN 520) ≥ 100 mm	2 EI 60 (V, I ⊕ ⊕) S - (300 Pa)	
	Metal studs gypsum plasterboard Type F (EN 520) ≥ 100 mm	2 EI 60 (V, I ⊕ ⊕) S - (300 Pa)	
	Metal studs gypsum plasterboard Type F (EN 520) ≥ 100 mm	2 EI 90 (V, I ⊕ ⊕) S - (500 Pa)	
	Mortar	1 EI 90 (V, I ⊕ ⊕) S - (300 Pa)	
	Stone wool + coating ≥ 140 kg/m <sup>3</sup>	1 EI 90 (V, I ⊕ ⊕) S - (300 Pa)	
	Stone wool Mulcol Multimastic FBI + coating	1 EI 60 (V, I ⊕ ⊕) S - (300 Pa)	
	Galvanised duct + stone wool + coating ≥ 140 kg/m <sup>3</sup> 2x50 mm	2 EI 90 (V, I ⊕ ⊕) S - (300 Pa)	
	Block glue	1 EI 90 (V, I ⊕ ⊕) S - (500 Pa)	
	Gypsum	1 EI 90 (V, I ⊕ ⊕) S - (500 Pa)	
	Gypsum blocks ≥ 70 mm	1 EI 90 (V, I ⊕ ⊕) S - (500 Pa)	
	Metal studs gypsum plasterboard Type A (EN 520) ≥ 75 mm	4 EI 30 (V, I ⊕ ⊕) S - (500 Pa)	
	Metal studs gypsum plasterboard Type F (EN 520) ≥ 75 mm	4 EI 30 (V, I ⊕ ⊕) S - (300 Pa)	
	Metal studs gypsum plasterboard Type A (EN 520) ≥ 100 mm	1 EI 60 (V, I ⊕ ⊕) S - (500 Pa)	
	Aerated concrete ≥ 100 mm	5 EI 60 (V, I ⊕ ⊕) S - (500 Pa)	
	Mortar	5 EI 90 (V, I ⊕ ⊕) S - (500 Pa)	
	Metal studs gypsum plasterboard Type A (EN 520) ≥ 100 - ≤ 125 mm	5 EI 60 (V, I ⊕ ⊕) S - (500 Pa)	
	Metal studs gypsum plasterboard Type F (EN 520) ≥ 80 mm	5 EI 60 (V, I ⊕ ⊕) S - (500 Pa)	

Performance	Installation	Classification
1 Type of installation: built-in, 0-360°. Minimal distances authorised with axis till 45°.	360°	EI 90 (V, I ⊕ ⊕) S - (500 Pa)
2 Type of installation: remote from the wall, 0/180°. Minimal distances authorised.		EI 90 (V, I ⊕ ⊕) S - (500 Pa)
3 Type of installation: built-in, 0-360°. Minimal distances authorised.		EI 90 (V, I ⊕ ⊕) S - (500 Pa)
4 Type of installation: built-in 0/180°. Minimal distances authorised.		EI 90 (V, I ⊕ ⊕) S - (500 Pa)

Essential characteristics	Performance	Installation	Classification
1 Type of installation: built-in, 0-360°. Minimal distances authorised with axis till 45°.	360°		EI 90 (V, I ⊕ ⊕) S - (500 Pa)
2 Type of installation: remote from the wall, 0/180°. Minimal distances authorised.			EI 90 (V, I ⊕ ⊕) S - (500 Pa)
3 Type of installation: built-in, 0-360°. Minimal distances authorised.			EI 90 (V, I ⊕ ⊕) S - (500 Pa)
4 Type of installation: built-in 0/180°. Minimal distances authorised.			EI 90 (V, I ⊕ ⊕) S - (500 Pa)

Essential characteristics	Performance	Installation	Classification
1 Type of installation: built-in, 0-360°. Minimal distances authorised with axis till 45°.	360°		EI 90 (V, I ⊕ ⊕) S - (500 Pa)
2 Type of installation: remote from the wall, 0/180°. Minimal distances authorised.			EI 90 (V, I ⊕ ⊕) S - (500 Pa)
3 Type of installation: built-in, 0-360°. Minimal distances authorised.			EI 90 (V, I ⊕ ⊕) S - (500 Pa)
4 Type of installation: built-in 0/180°. Minimal distances authorised.			EI 90 (V, I ⊕ ⊕) S - (500 Pa)

Essential characteristics	Performance	Installation	Classification
1 Type of installation: built-in, 0-360°. Minimal distances authorised with axis till 45°.	360°		EI 90 (V, I ⊕ ⊕) S - (500 Pa)
2 Type of installation: remote from the wall, 0/180°. Minimal distances authorised.			EI 90 (V, I ⊕ ⊕) S - (500 Pa)
3 Type of installation: built-in, 0-360°. Minimal distances authorised.			EI 90 (V, I ⊕ ⊕) S - (500 Pa)
4 Type of installation: built-in 0/180°. Minimal distances authorised.			EI 90 (V, I ⊕ ⊕) S - (500 Pa)

Nominal activation conditions/sensitivity: Pass  
 Response delay (response time): closure time Pass  
 Operational reliability: cycling Pass  
 Durability of response delay: Pass  
 Durability of operational reliability: Pass  
 Protection against corrosion according to EN 60668-2-52: Pass  
 Damper casing leakage according to EN 1751: ≥ class C

The performance of the product identified above is in conformity with the set of declared performance/s. This declaration of performance is issued, in accordance with Regulation (EU) No 305/2011, under the sole responsibility of the manufacturer identified above.

Signed for and on behalf of the manufacturer by:  
**Mathieu Steenland**, Technical Manager

*Mathieu Steenland*  
 Oosterzele, 03/2023



## Product presentation CR60

Optimised circular fire damper with a minimum fire resistance of 60 minutes. A minimal pressure loss is guaranteed thanks to the thin blade, the fusible link aligned with the blade, and the transmission located outside the tunnel. The damper is available in small diameters (starting from 100 mm). Its galvanised steel tunnel contributes to the light weight of the damper.

Fire dampers are installed where air ducts penetrate fire-resistant compartment walls. Their role is to restore the fire resistance grade of the penetrated wall and to prevent smoke propagation. Fire dampers are distinguished by their degree of fire resistance, by their aerulic properties as well as by their installation ease. Rf-Technologies' fire dampers are all CE marked. They can be equipped with various types of mechanisms depending on the specific needs linked to the project or to the local regulations.

- ✓ easy to install
- ✓ optimal free air passage and minimal pressure loss
- ✓ optimal acoustic performance
- ✓ higher net building volume through compact size
- ✓ air-tightness class C according to EN1751



- suitable for built-in and surface-mounted installation (CR60-1S)
- suitable for installation remote from the wall
- minimal distance allowed
- suitable for installation in rigid wall, rigid floor, flexible wall and flexible shaft wall (metal stud gypsum plasterboard wall)
- sealing with fire resistant stone wool boards allowed, also for asymmetric opening
- tested according to EN 1366-2 up to 500 Pa
- operating mechanism outside the wall
- maintenance-free
- for indoor use
- operating temperature: max. 50°C
- Hygiene certificate ([www.HYG.de](http://www.HYG.de))

1. casing in galvanised steel
2. damper blade
3. operating mechanism
4. rubber sealing ring
5. intumescent strip
6. positioning plate
7. sealing ring for damper blade
8. fusible link
9. product identification



**Range and dimensions CR60**

Exceeding damper blade: 20 mm for ØDn 315 mm

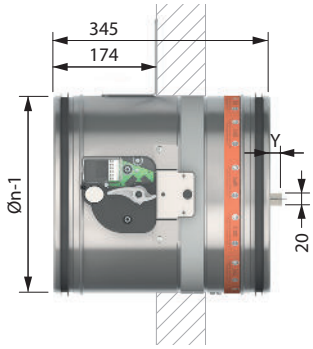

<b>ØDn (mm)</b>	<b>315</b>
x	-
y	20

<b>ØDn (mm)</b>	<b>100</b>	<b>125</b>	<b>150</b>	<b>160</b>	<b>180</b>	<b>200</b>	<b>250</b>	<b>300</b>	<b>315</b>
-----------------	------------	------------	------------	------------	------------	------------	------------	------------	------------

**Variant CR60-L500**

CR60 damper with a tunnel casing extension at the wall side to facilitate the connection to the duct when the supporting construction is thicker than 100 mm.

- 1. casing in galvanised steel
- 2. damper blade
- 3. operating mechanism
- 4. rubber sealing ring
- 5. intumescent strip
- 6. positioning plate
- 7. sealing ring for damper blade
- 8. fusible link
- 9. extended casing

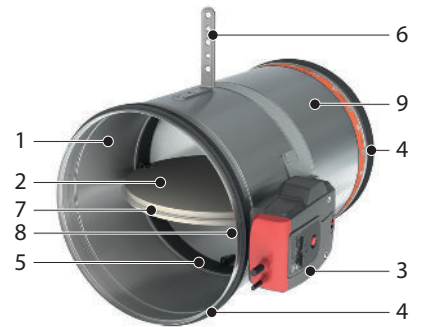

**Range and dimensions CR60-L500**

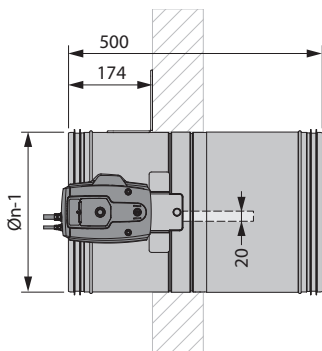

<b>ØDn (mm)</b>	<b>100</b>	<b>125</b>	<b>150</b>	<b>160</b>	<b>180</b>	<b>200</b>	<b>250</b>	<b>300</b>	<b>315</b>
-----------------	------------	------------	------------	------------	------------	------------	------------	------------	------------

## Variant CR60-1S

Surface mounted circular fire damper with a fire resistance of 60 minutes. The surface mounting ensures a fast (dry) installation. Its thin blade, the fusible link aligned with the blade, and the transmission located outside the tunnel guarantee a minimum pressure loss. The damper is available in small diameters (starting from 100 mm).

- ✓ no specific tools, no sealing required
- ✓ fast installation
- ✓ air-tightness class C according to EN1751



- suitable for surface-mount in rigid wall, rigid floor and light wall (metal stud gypsum plasterboard wall)
- not available in diameter 150, 180 and 300 mm
- minimal distance allowed

1. fire damper
2. upper mounting collar
3. lower mounting collar
4. graphite strip
5. sealing cold smoke
6. tape

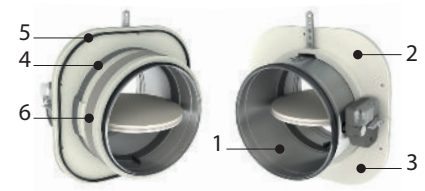

## Range and dimensions CR60-1S

Exceeding damper blade: 20 mm for ØDn 315 mm

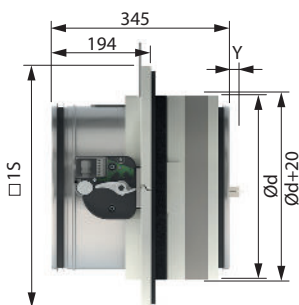

ØDn (mm)	315
x	-
y	20

ØDn (mm)	100	125	160	200	250	315
----------	-----	-----	-----	-----	-----	-----

ØDn	□1s	Ød	Ø
100	279	160	180
125	299	180	200
160	339	220	240
200	374	255	275
250	419	300	320
315	474	355	375



## Variant CR60-1S-L500

### Variant CR60-1S-L500

CR60-1S damper with a tunnel casing extension at the wall side to facilitate the connection to the duct when the supporting construction is thicker than 100 mm.

- ✓ no specific tools, no sealing required
- ✓ fast installation
- ✓ air-tightness class C according to EN1751



- suitable for surface-mount in rigid wall, rigid floor and light wall (metal stud gypsum plasterboard wall)
- not available in diameter 150, 180 and 300 mm
- minimal distance allowed

1. fire damper
2. upper mounting collar
3. lower mounting collar
4. graphite strip
5. sealing cold smoke
6. tape

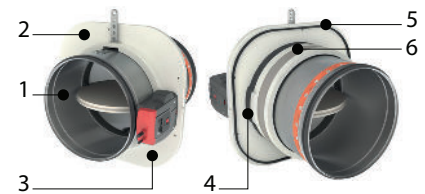

### Range and dimensions CR60-1S-L500

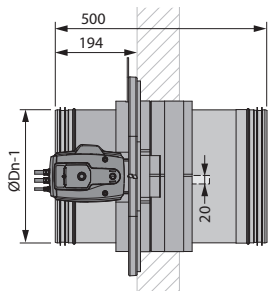

ØDn (mm)	100	125	160	200	250	315
----------	-----	-----	-----	-----	-----	-----

ØDn	1s	Ød	Ø
100	279	160	180
125	299	180	200
160	339	220	240
200	374	255	275
250	419	300	320
315	474	355	375



### CR60 + ONE

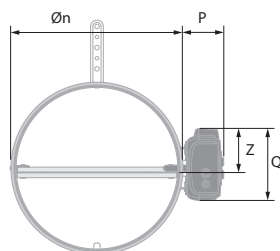





	MFUS	ONE (X)	BFL(T)
<b>P</b>	72	80	63
<b>Q</b>	123	136	100
<b>Z</b>	70	75	58





## Evolution - kits

	<b>KIT MFUS</b>	Automatic unlocking mechanism with fusible link
	<b>KIT ONE T 24 FDCB</b>	Spring return actuator ONE 24V (with fusible link T) + bipolar beginning- and end-of-range switch
	<b>KIT ONE T 24 FDCU</b>	Spring return actuator ONE 24V (with fusible link T) + unipolar beginning- and end-of-range switch
	<b>KIT ONE T 24 FDCU ST</b>	Spring return actuator ONE 24V (with fusible link T) + unipolar beginning- and end-of-range switch + plug (ST)
	<b>KIT ONE T 230 FDCB</b>	Spring return actuator ONE 230V (with fusible link T) + bipolar beginning- and end-of-range switch
	<b>KIT ONE T 230 FDCU</b>	Spring return actuator ONE 230V (with fusible link T) + unipolar beginning- and end-of-range switch
	<b>KIT ONE T 230 FDCU ST</b>	Spring return actuator ONE 230V (with fusible link T) + unipolar beginning- and end-of-range switch + plug (ST)
	<b>KIT ONE-X 24</b>	Spring return actuator ONE-X 24V (with fusible link T)
	<b>KIT ONE-X 230</b>	Spring return actuator ONE-X 230V (with fusible link T)

	<b>KIT BFL24</b>	Spring return actuator BFL 24V
	<b>KIT BFL24-ST</b>	Spring return actuator BFL 24V with plug (ST)
	<b>KIT BFL230</b>	Spring return actuator BFL 230V
	<b>KIT BFLT24</b>	Spring return actuator BFL 24V with thermo-electric fuse (T)
	<b>KIT BFLT24-ST</b>	Spring return actuator BFL 24V with thermo-electric fuse (T) and plug (ST)
	<b>KIT BFLT230</b>	Spring return actuator BFL 230V with thermo-electric fuse (T)
	<b>KIT BFLT230-ST</b>	Spring return actuator BFL 230V with thermo-electric fuse (T)
	<b>KIT BFN24</b>	Spring return actuator BFN 24V (BFN kits must be used instead of BFL kits for fire dampers produced before 1/7/2015)
	<b>KIT FDCU MFUS(P)</b>	Limit switch 'open/closed'

	<b>KIT SN2 BFL/BFN</b>	Auxiliary limit switch 'open/closed'
	<b>KIT ZBAT 72</b>	Black spare part for thermo-electric fuse for BFLT/BFNT
	<b>KIT FUS 72 MFUS(P)</b>	Fusible link 72°C
	<b>FUS72 ONE</b>	Fusible link 72°C
	<b>MECT</b>	Testbox for mechanisms 24/48 V (magnet, motor, beginning and end of range switches)
	<b>EPP CR60/120</b>	Kit with 4 cover plates (gypsum plasterboard 12.5 mm) for CR60, CR120 in light wall.
	<b>INSPECAM</b>	Sturdy digital endoscope for the internal inspection of fire dampers through an optional inspection opening. The endoscope features a 1 meter long probe with a diameter of 8,2 mm equipped with a dimmable LED, a removable 4x zoom, a colour LCD monitor 3.5". Photographic capture 3MP and video capture 720P.

## Options - at the time of order

	<b>1S</b>	Collar for circular surface-mount 1s (100-315 mm)
	<b>UL</b>	Inspection opening to visually determine the state and the position of the damper, by using an endoscope.

## Storage and handling

As this product is a safety element, it should be stored and handled with care.

### Avoid:

- any kind of impact or damage
- contact with water
- deformation of the casing

### It is recommended:

- to unload in a dry area
- not to flip or roll the product to move it
- not to use the damper as a scaffold, working table, etc.
- not to store smaller dampers inside larger ones

## Installation

### General points

- The installation must comply with the installation manual and the classification report.
- Axis orientation: see the declaration of performance.
- Avoid obstruction of adjoining ducts.
- Product installation: always with closed damper blade.
- Verify if the blade can move freely.
- Please observe safety distances with respect to other construction elements. The operating mechanism must also remain accessible: allow for a clearance of 200 mm around the housing.
- The air tightness class will be maintained if the damper is installed according to the installation manual.
- Rf-t fire dampers are always tested in standardised constructions according to EN 1366-2. The achieved results are valid for similar supporting constructions with a fire resistance, thickness and density equal or superior to the supporting construction used during the test.
- If the wall thickness exceeds the minimum thickness specified in our installation instructions, the following conditions apply to the sealing depth:
  - For flexible walls and sandwich panel system walls, the seal must always be applied over the full depth of the wall.
  - With rigid walls, rigid floors and plaster block walls, the minimum sealing depth as indicated in our installation instructions (often equal to the minimum wall thickness) is sufficient. Apply the seal at the height of the damper blade (from the wall limit indication).
- When installing a fire damper in a flexible metal stud wall, some installation methods do not require reinforcing profiles around the wall opening from a fire protection point of view (see below). Always follow the general instructions of the manufacturer of these wall systems when building this type of wall.
- The damper must remain accessible for inspection and maintenance.
- Schedule at least 2 visual checks each year.

		TEST
2021	<input checked="" type="checkbox"/>	<input checked="" type="checkbox"/>
2022	<input checked="" type="checkbox"/>	<input type="checkbox"/>
2023	<input type="checkbox"/>	<input type="checkbox"/>
2024	<input type="checkbox"/>	<input type="checkbox"/>
2025	<input type="checkbox"/>	<input type="checkbox"/>

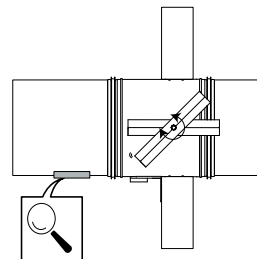

## Installation at a minimal distance from another damper or from an adjacent supporting construction

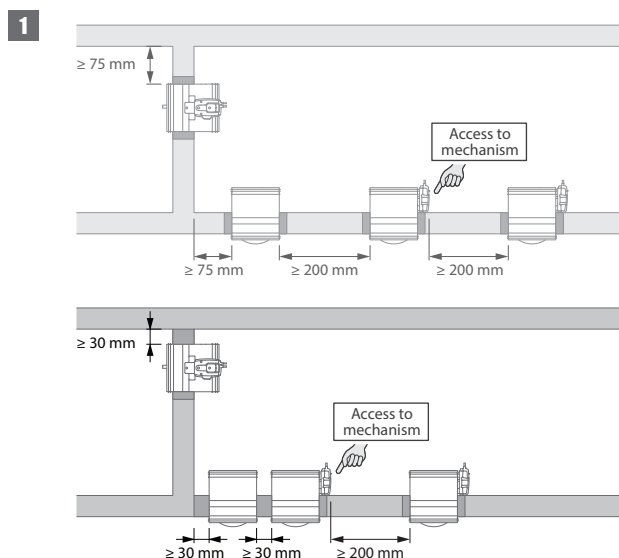

### 1. Principle

According to the European test standard, a fire damper must be installed at a minimum distance of 75 mm from an adjacent wall and 200 mm from another damper, unless the solution was tested at a shorter distance.

This range of Rf-t fire dampers has been successfully tested and can be installed in a vertical or horizontal supporting construction, at a distance below the minimum set by the standard.

For circular dampers, the minimal distance is set to 30 mm.

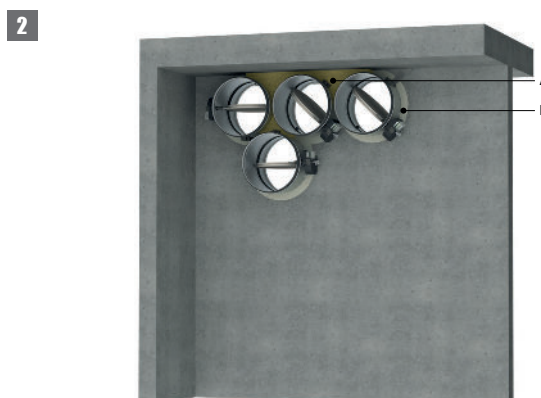

### 2. Certified solution

For the Rf-t fire dampers, the solution consists of the following elements: A: Universal sealing for minimal distance; B: Sealing compliant with existing classifications (Declaration of Performance).

A. Sealing of the opening at the side with minimal distances between damper and wall/ceiling or another fire damper: rigid stone wool panels ( $150 \text{ kg/m}^3$ ) are applied to a depth of min. 400 mm, of which 150 mm on the mechanism side of the wall. On the non-mechanism side of the wall, the stone wool panels must be at least flush with the wall. The surface of this sealing is set between the axes (centres) of the dampers.

B. Sealing of the rest of the opening according to the existing classifications for the fire damper (Declaration of Performance). This also applies to circular dampers that are mounted at a minimum distance from one another (30 to 200 mm) but at a distance greater than 75 mm from a wall/ceiling. Detailed information for each wall/sealing combination can be found in the respective installation methods.

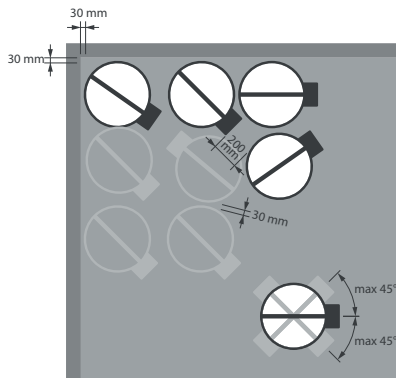
**3**

### 3. Restrictions

The orientation of the blade axis should be horizontal or oriented at a maximum of 45°.

A maximum of 3 circular dampers can be installed at a minimum distance from one another, both vertically and horizontally (with a maximum cluster of 4 dampers).

Note: when sealing the opening with panels of fire resistant stone wool, the maximum number of dampers also depends on the maximum “blank seal” allowed for the selected sealing material. Please refer to the manufacturer’s instructions for this information.

Note: Separate conditions apply for installation in flexible shaft wall. Detailed information can be found in the relevant installation methods.

## Installation in rigid wall and floor

The product was tested and approved in:

Range	Wall type	Sealing	Classification
Ø 100-315 mm	Rigid wall	Aerated concrete $\geq 100$ mm	Mortar / Gypsum
Ø 100-315 mm	Rigid floor	Aerated concrete $\geq 100$ mm	Mortar

1

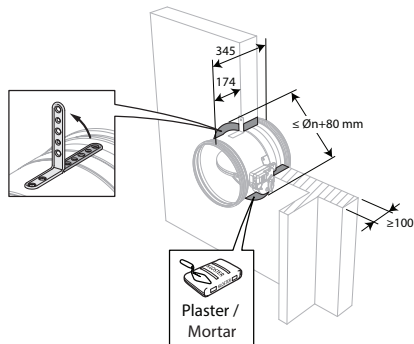

2

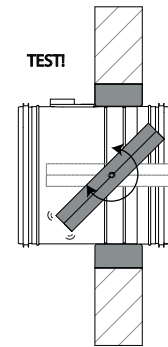

3

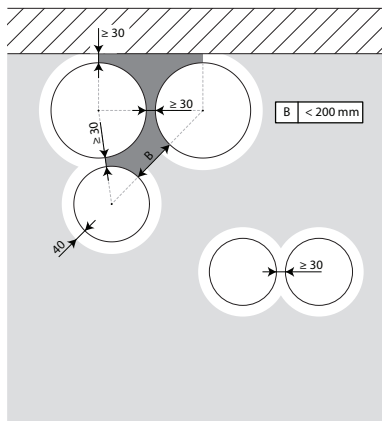

3. The dampers can be installed at a minimum distance ( $\geq 30$  mm) from an adjacent wall or from another damper.

4

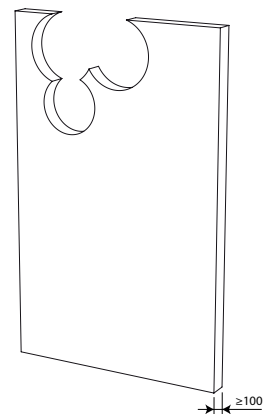

4. Make the necessary openings ( $\leq \text{Dn} + 80$  mm) in the wall.

5

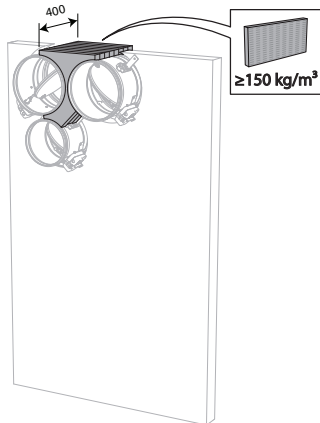

5. Mount the dampers in the opening.  
 Apply rigid stone wool panels ( $\geq 150 \text{ kg/m}^3$ ) to a depth of 400 mm (150 mm on the mechanism side of the wall) to seal the opening at the side with minimal distances.  
 The surface of this sealing is set between the axes (centres) of the dampers.  
 Caution: the opening is sealed according to the existing classification (see next point) when:
- 2 fire dampers are installed at a minimum distance from one another but at a normal distance ( $\geq 75 \text{ mm}$ ) from the wall or floor/ceiling.
  - One single (no cluster) fire damper is located at a minimum distance ( $\leq 75 \text{ mm}$ ) from a wall or floor/ceiling.

6

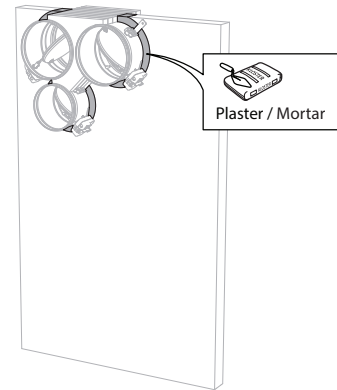

6. Seal the rest of the opening with standard mortar or gypsum (only for vertical walls).



## Installation in flexible wall (metal stud gypsum plasterboard wall)

The product was tested and approved in:

Range	Wall type	Sealing	Classification
Ø 100-250 mm	Flexible wall	Stone wool $\geq 40 \text{ kg/m}^3$ + cover plates	El 60 ( $v_e \leftrightarrow o$ ) S - (500 Pa)

1

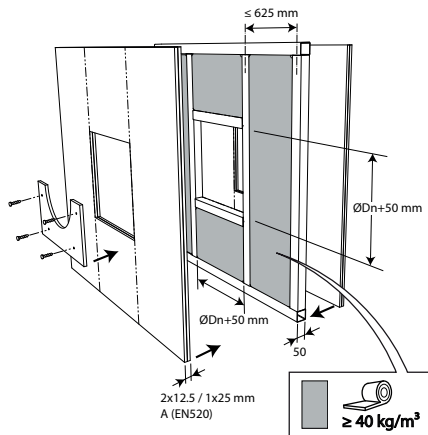

2

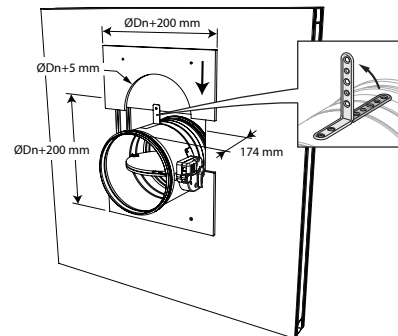

3

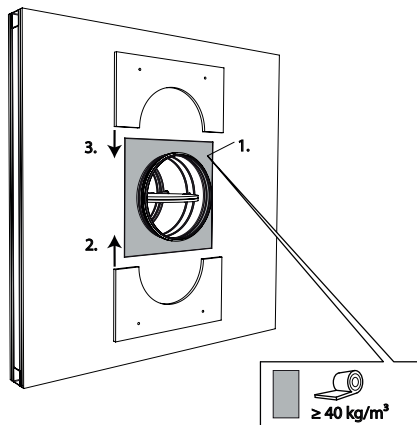

4

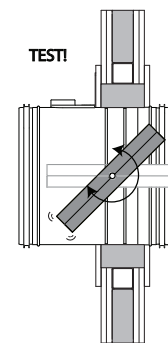

5

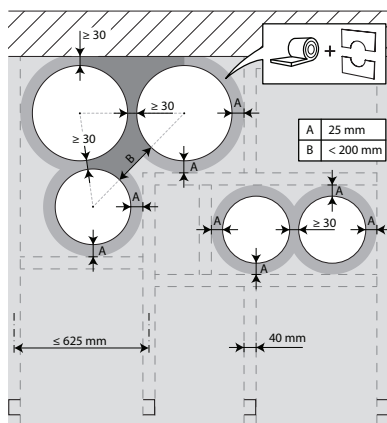

6

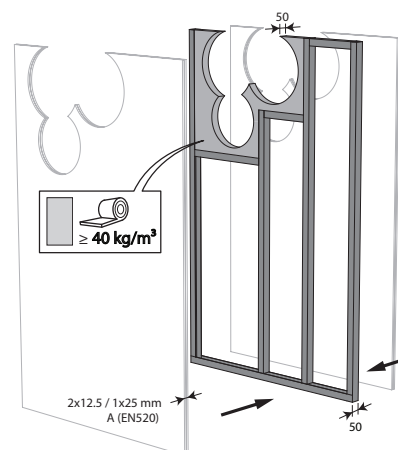

5. The dampers can be installed at a minimum distance ( $\geq 30$  mm) from an adjacent wall or from another damper.

6. Build the drywall and foresee horizontal and vertical studs around the opening.

In the opening around the dampers ( $D_n + 50$  mm), the void between the gypsum boards is filled with stone wool with a minimum density of  $40 \text{ kg/m}^3$ .

7

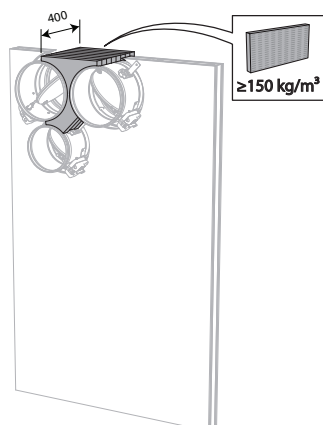

7. Mount the dampers in the opening.  
Apply rigid stone wool panels ( $\geq 150 \text{ kg/m}^3$ ) to a depth of 400 mm (150 mm on the mechanism side of the wall) to seal the opening at the side with minimal distances. The surface of this sealing is set between the axes (centres) of the dampers.

Caution: the opening is sealed according to the existing classification (see next point) when:

- 2 fire dampers are installed at a minimum distance from one another but at a normal distance ( $\geq 75 \text{ mm}$ ) from the wall or floor/ceiling.
- One single (no cluster) fire damper is located at a minimum distance ( $\leq 75 \text{ mm}$ ) from a wall or floor/ceiling.

8

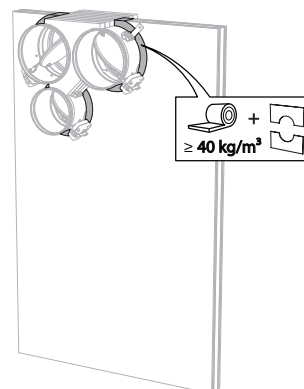

8. Seal the rest of the opening with standard stone wool  $40 \text{ kg/m}^3$  across the entire wall thickness.

9

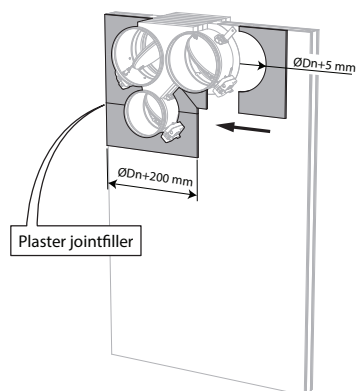

9. Apply cover plates (gypsum plasterboards) to finish the surface at both sides.  
Seal off the space between the plasterboards with jointfiller.



5

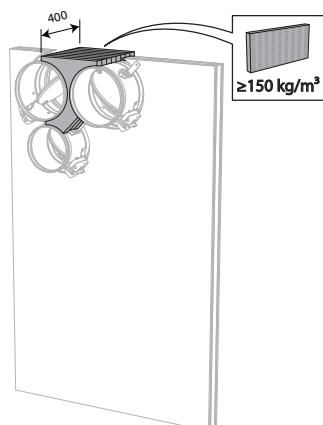

5. Mount the dampers in the opening.  
 Apply rigid stone wool panels ( $\geq 150 \text{ kg/m}^3$ ) to a depth of 400 mm (150 mm on the mechanism side of the wall) to seal the opening at the side with minimal distances.  
 The surface of this sealing is set between the axes (centres) of the dampers.
- Caution: the opening is sealed according to the existing classification (see next point) when:
- 2 fire dampers are installed at a minimum distance from one another but at a normal distance ( $\geq 75 \text{ mm}$ ) from the wall or floor/ceiling.
  - One single (no cluster) fire damper is located at a minimum distance ( $\leq 75 \text{ mm}$ ) from a wall or floor/ceiling.

6

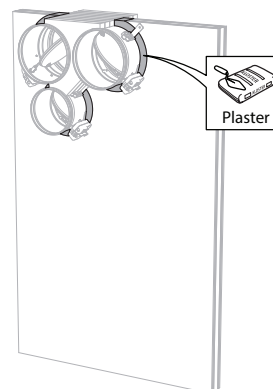

6. Seal the rest of the opening with standard gypsum across the entire wall thickness.

## Installation in flexible wall (metal stud gypsum plasterboard wall), sealing with mortar

The product was tested and approved in:

Range	Wall type	Sealing	Classification
Ø 100-315 mm	Flexible wall	Mortar	El 90 (v <sub>e</sub> i ↔ o) S - (300 Pa)

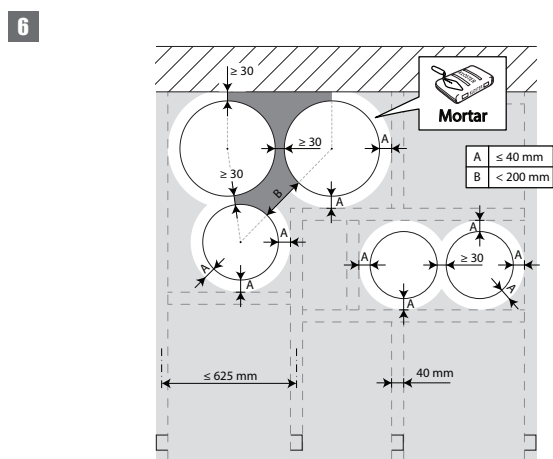
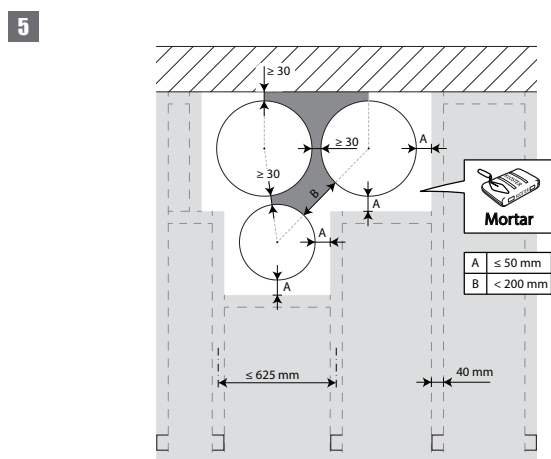
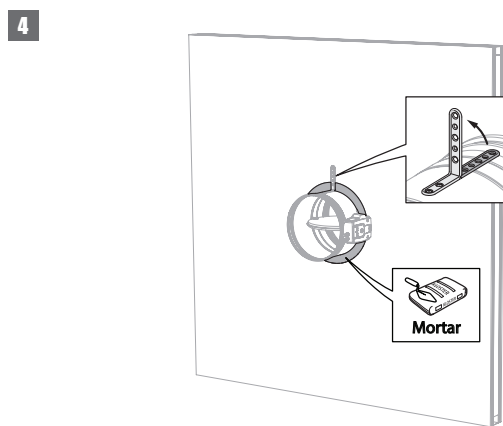
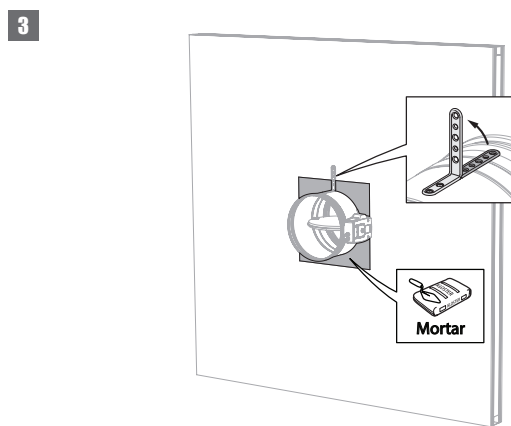
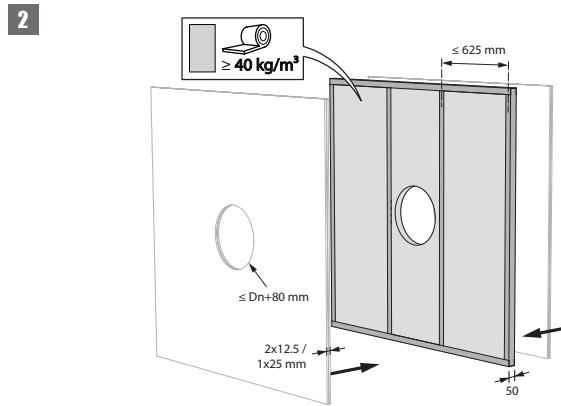
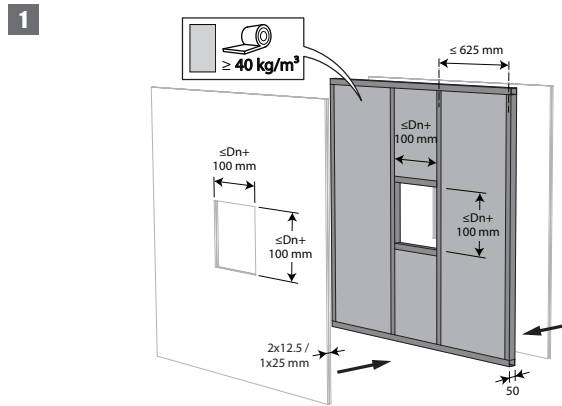

5. The dampers can be installed at a minimum distance ( $\geq 30$  mm) from an adjacent wall or from another damper.

7

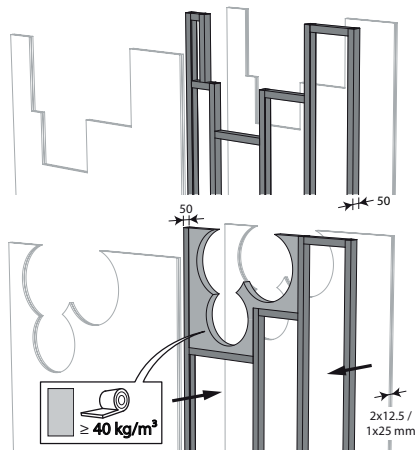

7. Build the drywall and foresee horizontal and vertical studs around the opening.

For a circular wall opening, the space between the plasterboard sheets is partially (up to  $D_n + 40 \text{ mm}$ ) filled with stone wool with a minimum density of  $40 \text{ kg/m}^3$ .

9

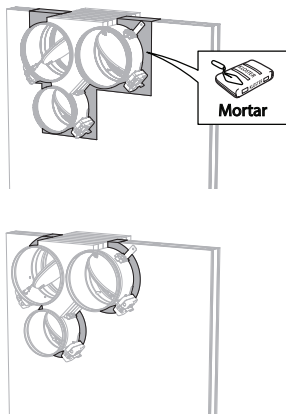

9. Seal the rest of the opening with standard mortar across the entire wall thickness.

8

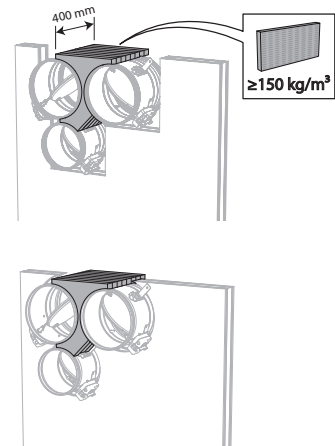

8. Mount the dampers in the opening.

Apply rigid stone wool panels ( $\geq 150 \text{ kg/m}^3$ ) to a depth of 400 mm (150 mm on the mechanism side of the wall) to seal the opening at the side with minimal distances.

The surface of this sealing is set between the axes (centres) of the dampers.

Caution: the opening is sealed according to the existing classification (see next point) when:

- 2 fire dampers are installed at a minimum distance from one another but at a normal distance ( $\geq 75 \text{ mm}$ ) from the wall or floor/ceiling.
- One single (no cluster) fire damper is located at a minimum distance ( $\leq 75 \text{ mm}$ ) from a wall or floor/ceiling.

## Installation in gypsum block wall

The product was tested and approved in:

Range	Wall type	Sealing	Classification
Ø 100-315 mm	Flexible wall	Gypsum blocks ≥ 70 mm	Block glue
			El 90 (v <sub>e</sub> i ↔ o) S - (500 Pa)

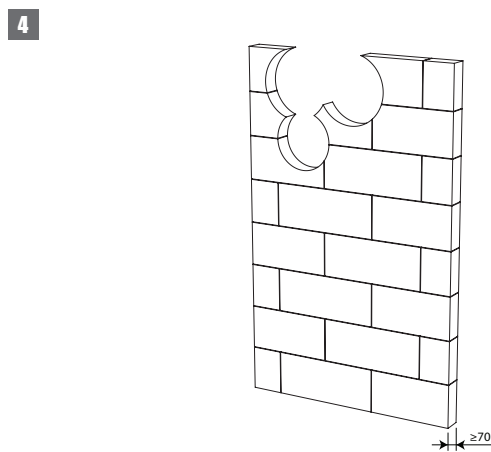
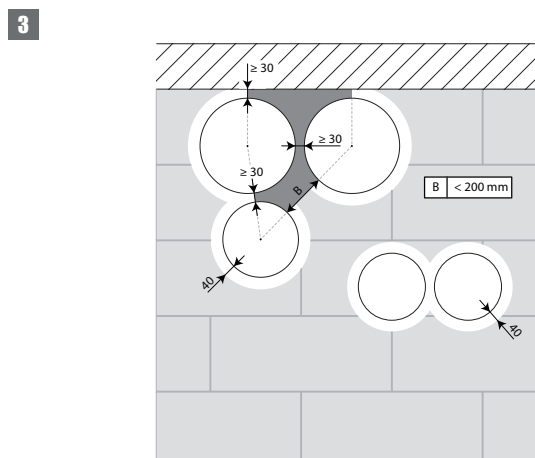
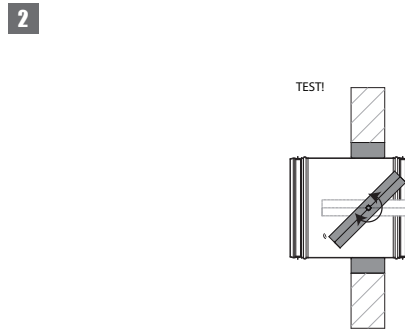
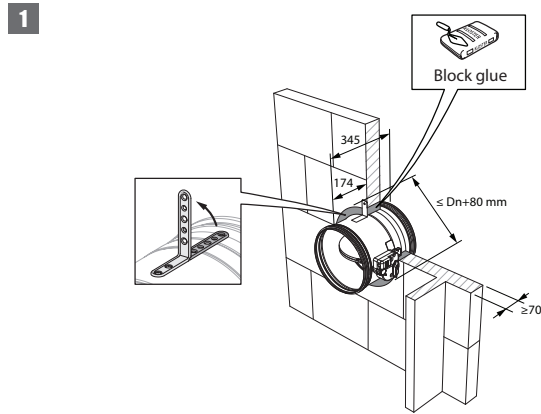

3. The dampers can be installed at a minimum distance from an adjacent wall or from another damper.

4. Make the necessary openings ( $\leq Dn + 80$  mm) in the wall.

5

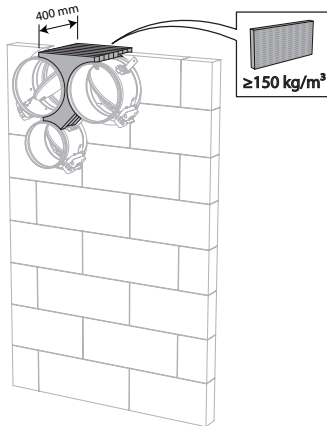

5. Mount the dampers in the opening.  
 Apply rigid stone wool panels ( $\geq 150 \text{ kg/m}^3$ ) to a depth of 400 mm (150 mm on the mechanism side of the wall) to seal the opening at the side with minimal distances.  
 The surface of this sealing is set between the axes (centres) of the dampers.
- Caution: the opening is sealed according to the existing classification (see next point) when:
- 2 fire dampers are installed at a minimum distance from one another but at a normal distance ( $\geq 75 \text{ mm}$ ) from the wall or floor/ceiling.
  - One single (no cluster) fire damper is located at a minimum distance ( $\leq 75 \text{ mm}$ ) from a wall or floor/ceiling.

6

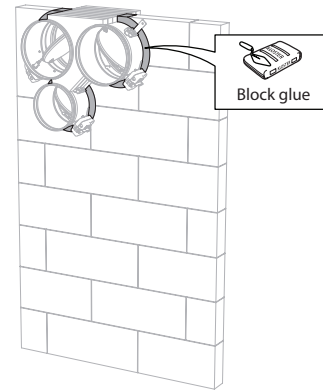

6. Seal the rest of the opening with block glue across the entire wall thickness.



## Installation in flexible and rigid wall, sealing with rigid rock wool boards with coating

The product was tested and approved in:

Range	Wall type	Sealing	Classification
Ø 100-315 mm	Rigid wall	Aerated concrete ≥ 100 mm	Stone wool + coating ≥ 140 kg/m <sup>3</sup>
Ø 100-315 mm	Flexible wall	Metal studs gypsum plasterboard Type A (EN 520) ≥ 100 mm	Stone wool + coating ≥ 140 kg/m <sup>3</sup>
Ø 100-315 mm	Flexible wall	Metal studs gypsum plasterboard Type F (EN 520) ≥ 100 mm	Stone wool + coating ≥ 140 kg/m <sup>3</sup>
Ø 100-315 mm	Rigid wall	Aerated concrete ≥ 100 mm	Stone wool Mulcol Multimastic FB1 + coating
Ø 100-315 mm	Flexible wall	Metal studs gypsum plasterboard Type F (EN 520) ≥ 100 mm	Stone wool Mulcol Multimastic FB1 + coating

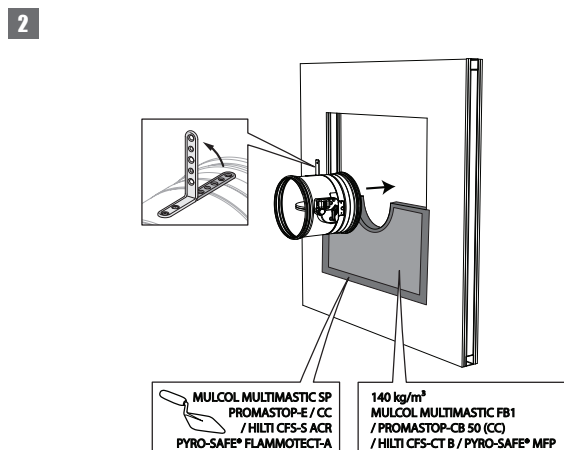
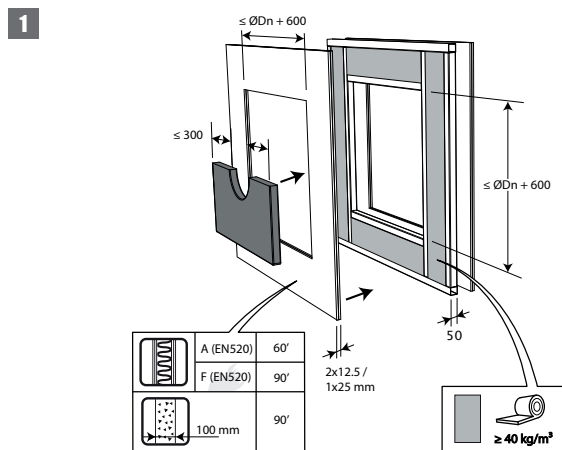

1. The opening around the damper is sealed with 2 layers of 50 mm-thick mineral wool panels with fire resistant coating on one side (type PROMASTOP-CB 50 / PROMASTOP-CB/CC 50 / HILTI CFS-CT B / Mulcol Multimastic FB1 / PYRO-SAFE® MFP).

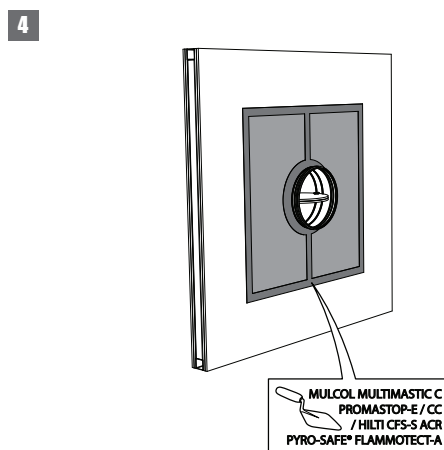
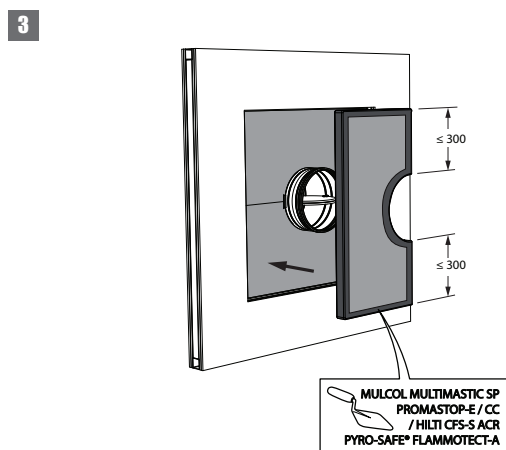

3. The joints on these 2 layers must be installed staggered and covered all around the edge with coating (type PROMASTOP-E / PROMASTOP-CC / HILTI CFS-S-ACR / Mulcol Multimastic SP / PYRO-SAFE® FLAMMOTECT-A).

5

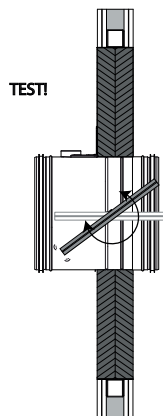

6

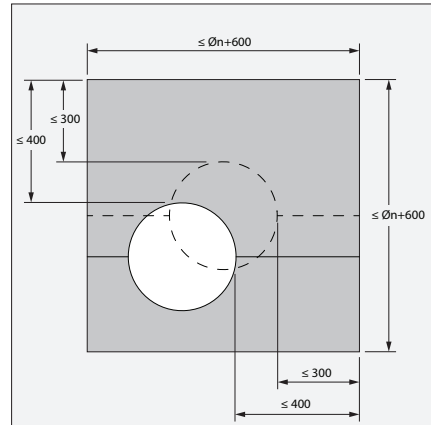

6. The damper does not need to be centered in the opening (with max dimensions fire damper + 600 mm). The maximal distance between the damper and the edge of the opening is 400 mm.

7

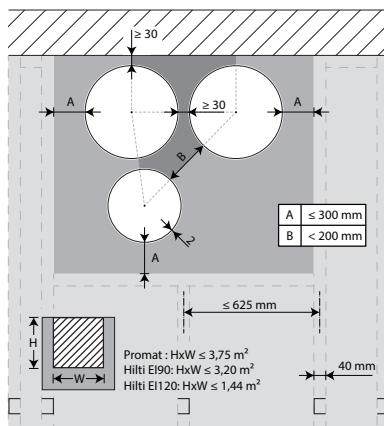

7. The dampers can be installed at a minimum distance ( $\ge 30$  mm) from an adjacent wall or from another damper.

8

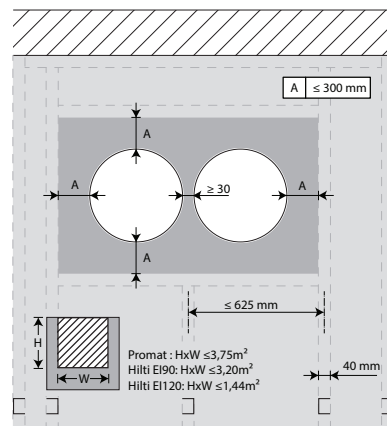

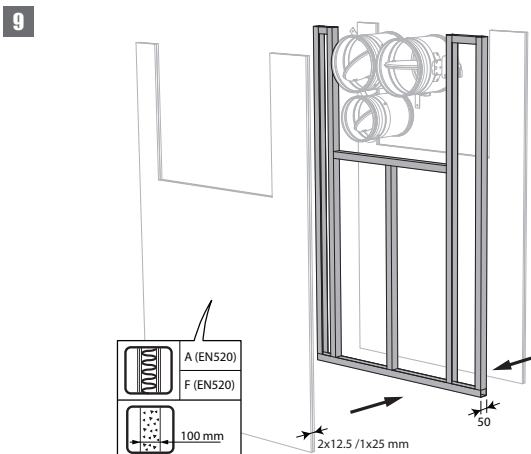

9. Build the drywall and foresee horizontal and vertical studs around the opening.  
Mount the dampers in the opening.

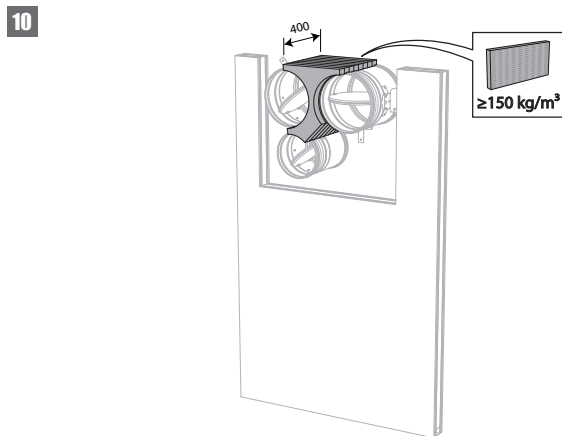

10. Apply rigid stone wool panels ( $\geq 150 \text{ kg/m}^3$ ) to a depth of 400 mm (150 mm on the mechanism side of the wall) to seal the opening at the side with minimal distances.

The surface of this sealing is set between the axes (centres) of the dampers.

Caution: the opening is sealed according to the existing classification (see next point) when:

- 2 fire dampers are installed at a minimum distance from one another but at a normal distance ( $\geq 75 \text{ mm}$ ) from the wall or floor/ceiling.
- One single (no cluster) fire damper is located at a minimum distance ( $\leq 75 \text{ mm}$ ) from a wall or floor/ceiling.

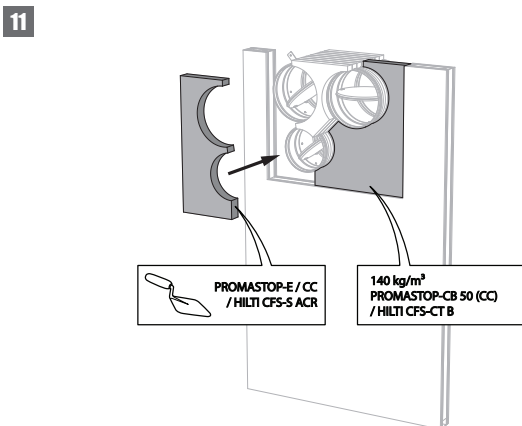

11. Seal the rest of the opening with 2 layers of 50 mm-thick coated rigid mineral wool panels (see above).

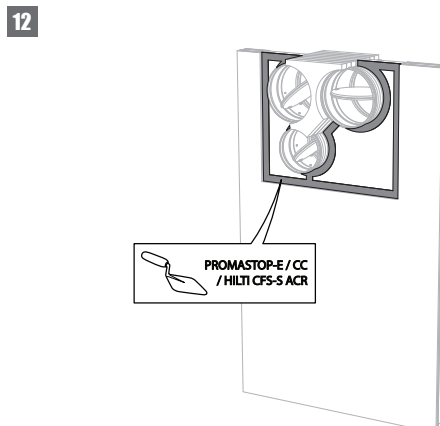

## Installation in rigid floor, sealing with rigid rock wool boards with coating

The product was tested and approved in:

Range	Wall type	Sealing	Classification
Ø 100-315 mm	Rigid floor	Aerated concrete ≥ 150 mm Stone wool + coating ≥ 140 kg/m <sup>3</sup>	El 90 (h <sub>o</sub> i ↔ o) S - (300 Pa)

1

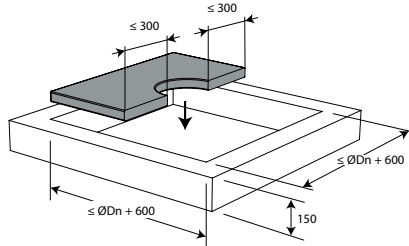

2

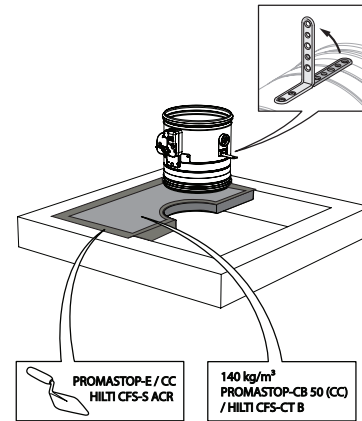

1. The opening around the damper is sealed with 2 layers of 50 mm-thick mineral wool panels with fire resistant coating on one side (type PROMASTOP-CB 50 / PROMASTOP-CB/CC 50 / HILTI CFS-CT B).

3

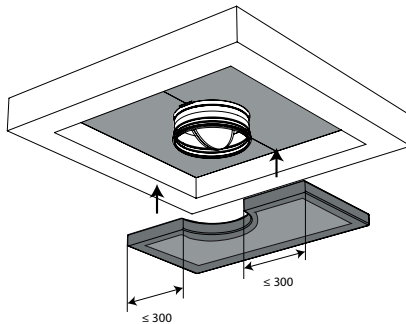

4

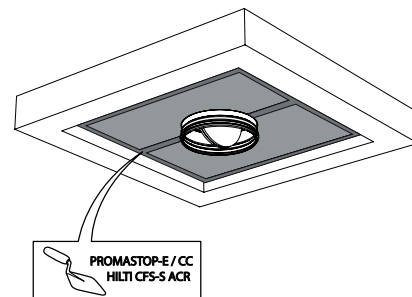

3. The joints on these 2 layers must be installed staggered and covered all around the edge with coating (type PROMASTOP-E / PROMASTOP-CC / HILTI CFS-S-ACR).

5

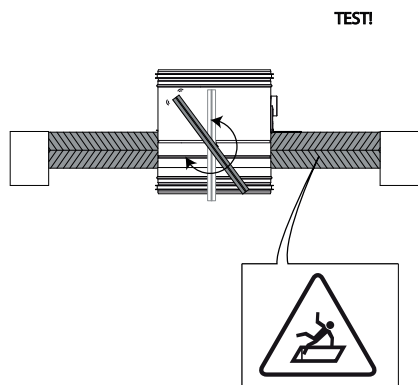

6

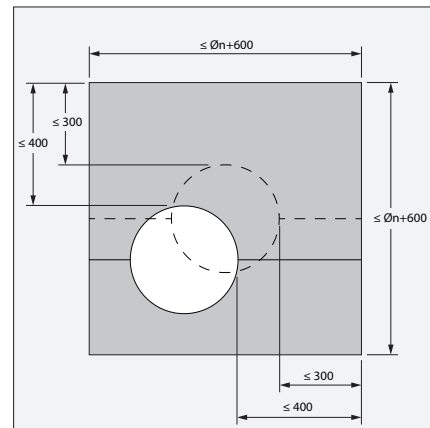

6. The damper does not need to be centered in the opening (with max dimensions fire damper + 600 mm). The maximal distance between the damper and the edge of the opening is 400 mm.

7

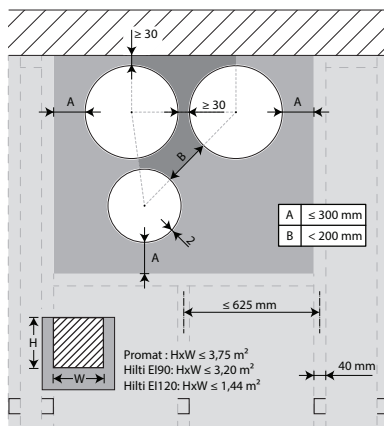

7. The dampers can be installed at a minimum distance ( $\ge 30$  mm) from an adjacent wall or from another damper.

8

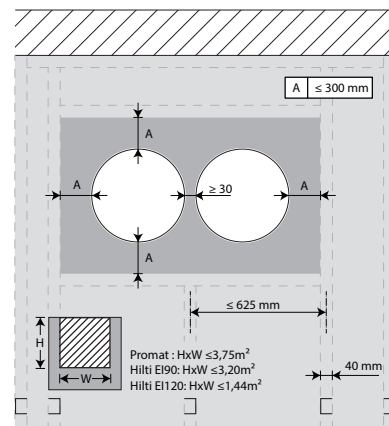

8. For details, please refer to 'Installation in flexible and rigid wall, sealing with rigid rock wool boards with coating'

## Installation in rigid wall and floor with collar for surface-mount 1s

The product was tested and approved in:

Range	Wall type	Sealing	Classification
CR60-1S Ø 100-315 mm	Rigid wall	Aerated concrete $\geq 100$ mm	El 60 ( $v_e$ i $\leftrightarrow$ o) S - (500 Pa)
CR60-1S Ø 100-315 mm	Rigid floor	Aerated concrete $\geq 100$ mm	El 60 ( $h_o$ i $\leftrightarrow$ o) S - (500 Pa)
CR60-1S Ø 100-315 mm	Rigid floor	Aerated concrete $\geq 100$ mm	El 90 ( $h_o$ i $\rightarrow$ o) S - (500 Pa)

1

$\varnothing D_n$	$\square 1s$	$\varnothing d$	$\varnothing$ 
100	279	160	180
125	299	180	200
160	339	220	240
200	374	255	275
250	419	300	320
315	474	355	375

2

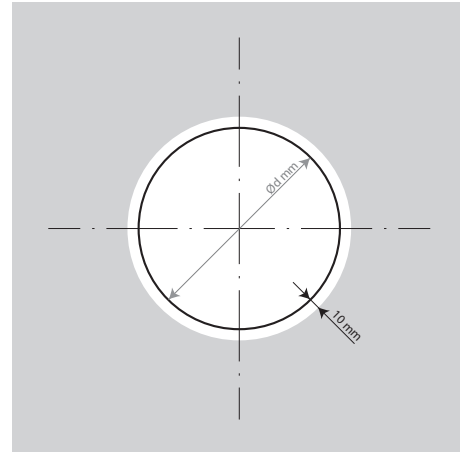

3

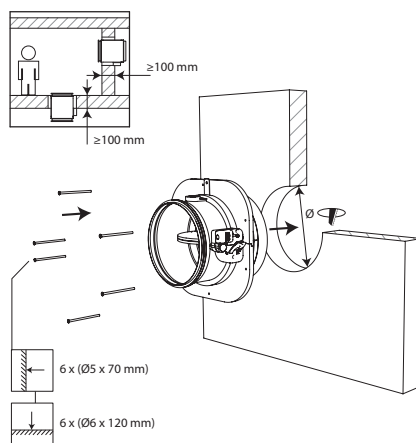

4

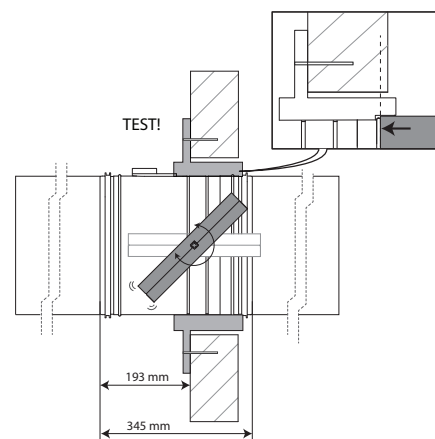

5

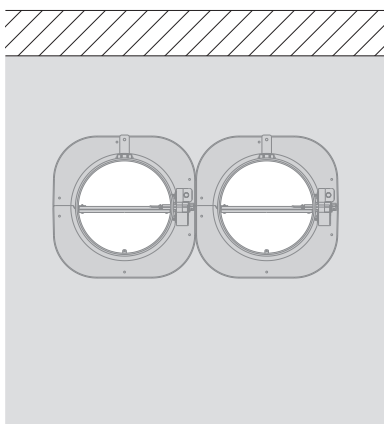

5. The dampers can be installed at a minimum distance from an adjacent wall or from another damper.

## Installation in flexible wall with collar for surface-mount 1s

The product was tested and approved in:

Range	Wall type	Sealing	Classification
CR60-1S Ø 100-315 mm	Flexible wall	Metal studs gypsum plasterboard Type A (EN 520) $\geq 100 - \leq 125$ mm	Not applicable
			El 60 ( $v_e$ i $\leftrightarrow$ o) S - (500 Pa)

1

$\varnothing D_n$	$\square 1s$	$\varnothing d$	$\varnothing$ 
100	279	160	180
125	299	180	200
160	339	220	240
200	374	255	275
250	419	300	320
315	474	355	375

2

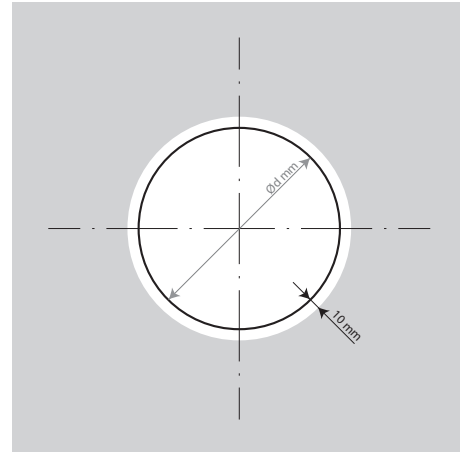

3

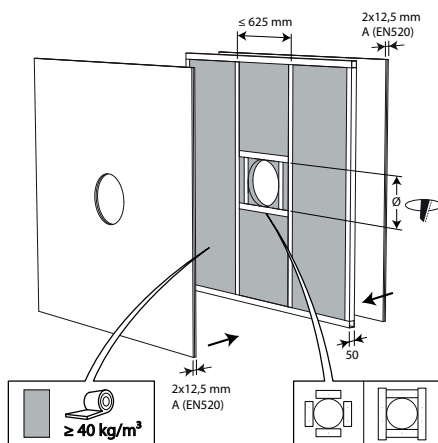

4

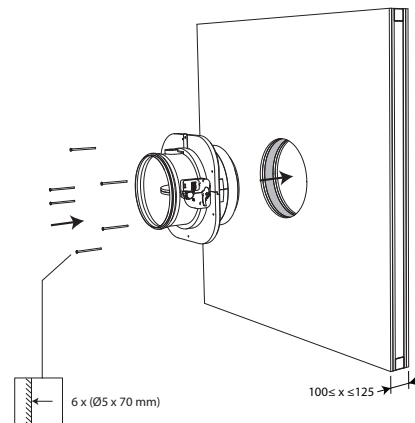

5

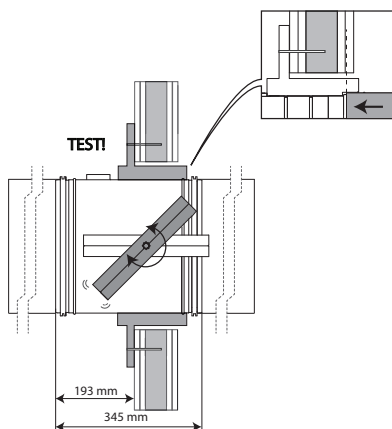

6

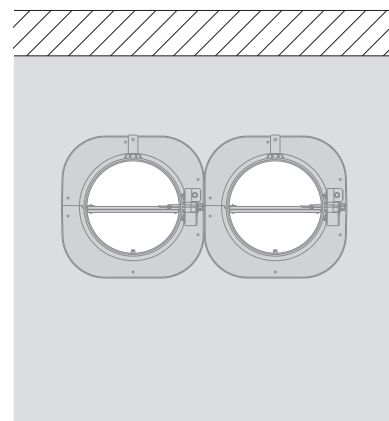

6. The dampers can be installed at a minimum distance from an adjacent wall or from another damper.

## Installation in shaft wall with collar for surface-mount 1s

The product was tested and approved in:

Range	Wall type	Sealing	Classification
CR60-1S Ø 100-315 mm	Asymmetrical flexible wall (shaft wall)	Metal studs gypsum plasterboard Type F (EN 520) $\geq 80$ mm	Not applicable
			El 60 ( $v_e i \leftrightarrow o$ ) S - (500 Pa)

1

$\varnothing D_n$	□ 1s	$\varnothing d$	$\varnothing$ 
100	279	160	180
125	299	180	200
160	339	220	240
200	374	255	275
250	419	300	320
315	474	355	375

2

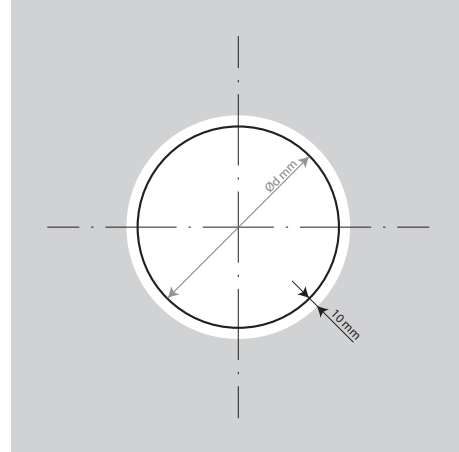

3

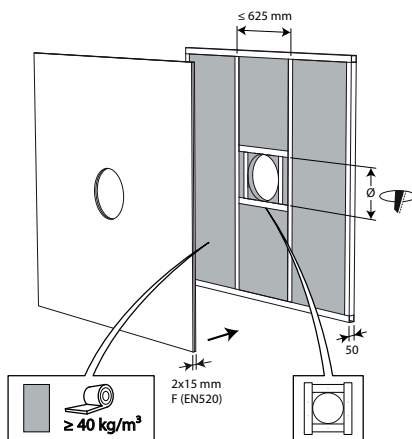

4

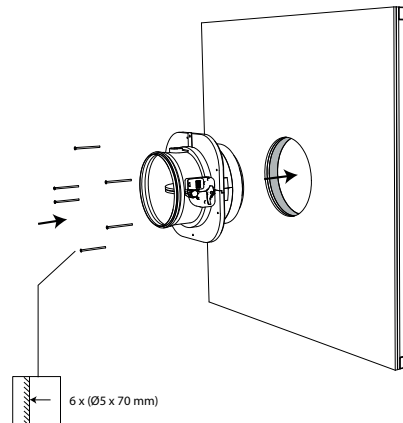

5

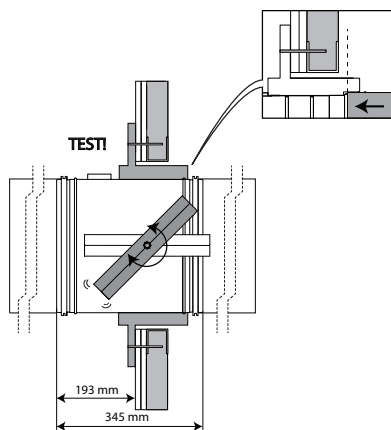

6

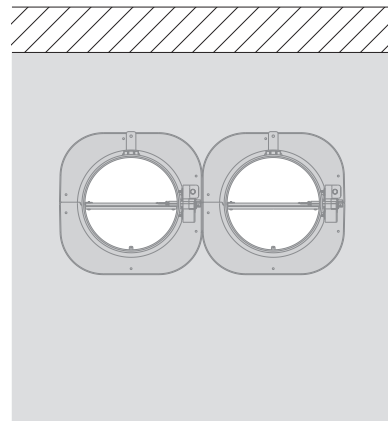

6. The dampers can be installed at a minimum distance from an adjacent wall or from another damper.



## Installation in shaft wall, sealing with gypsum

The product was tested and approved in:

Range	Wall type	Sealing	Classification
Ø 100-315 mm	Asymmetrical flexible wall (shaft wall) Metal studs gypsum plasterboard Type A (EN 520) $\geq 75$ mm	Gypsum	El 30 ( $v_e$ i $\leftrightarrow$ o) S - (500 Pa)

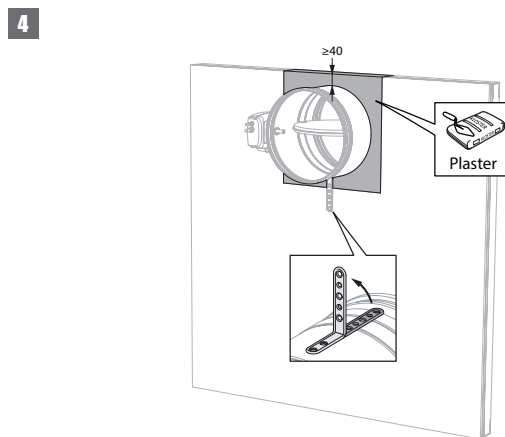
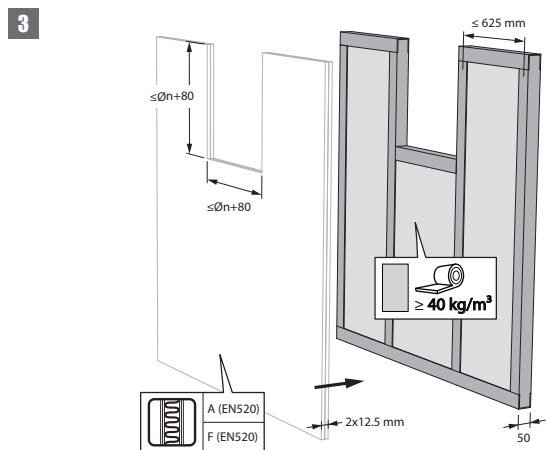
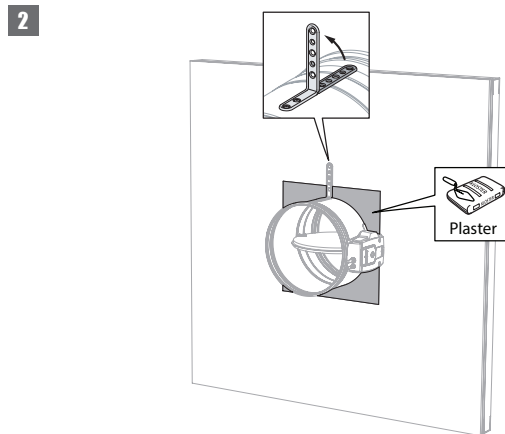
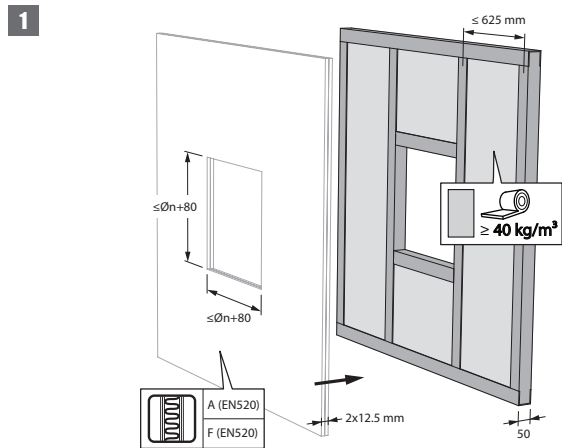

3. The dampers can be installed at a minimum distance ( $\geq 40$  mm) from a ceiling or floor slab.

## Installation in shaft wall, sealing with rigid rock wool boards with coating

The product was tested and approved in:

Range	Wall type	Sealing	Classification
Ø 100-315 mm	Asymmetrical flexible wall (shaft wall) Metal studs gypsum plasterboard Type F (EN 520) ≥ 75 mm	Stone wool + coating ≥ 140 kg/m <sup>3</sup>	El 30 (v <sub>e</sub> i ↔ o) S - (300 Pa)

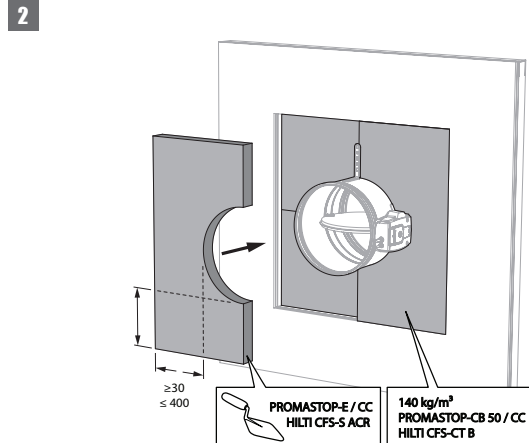
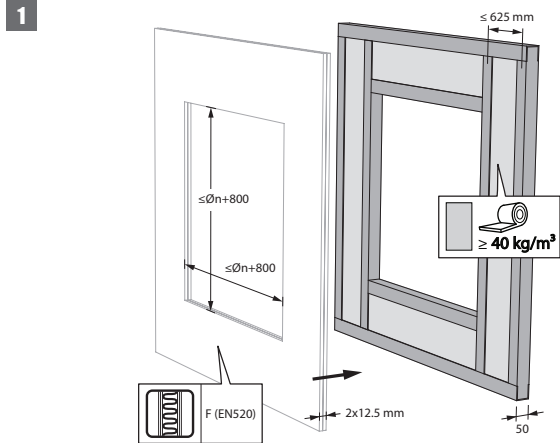

2. The opening around the damper is sealed with 2 hard rock wool slabs of 50 mm. These boards should be placed in a slanted position and the joints should be covered all around with filling paste.

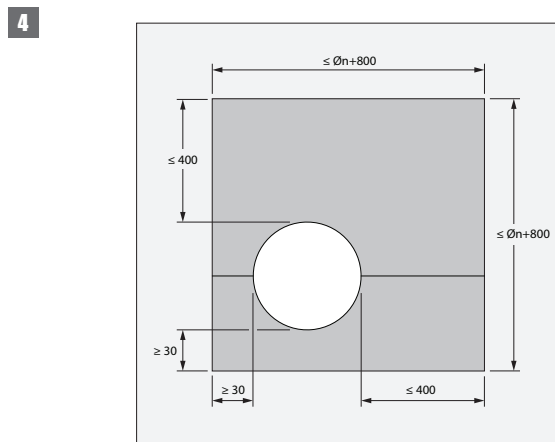
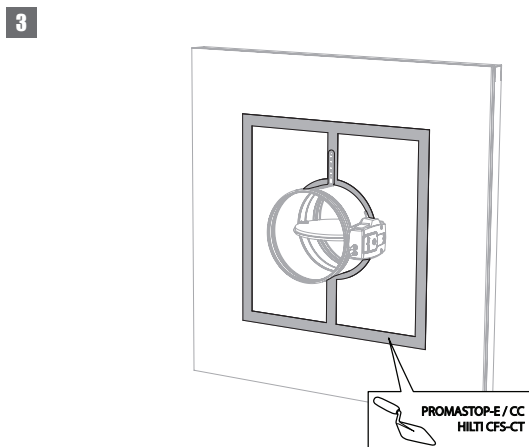

4. The damper does not need to be centered in the opening (with max dimensions Ø fire damper + 800 mm). The maximal distance between the damper and the edge of the opening is 400 mm.

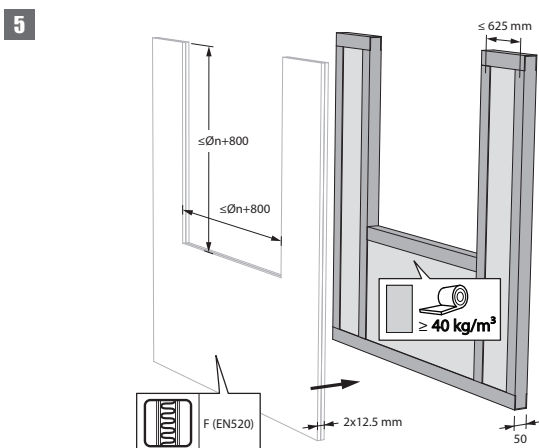

5. The dampers can be installed at a minimum distance ( $\geq 30$  mm) from a ceiling or floor slab.

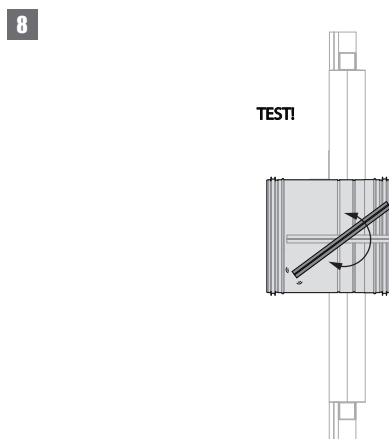
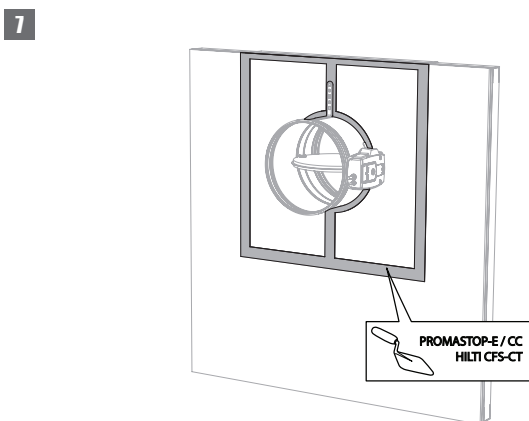
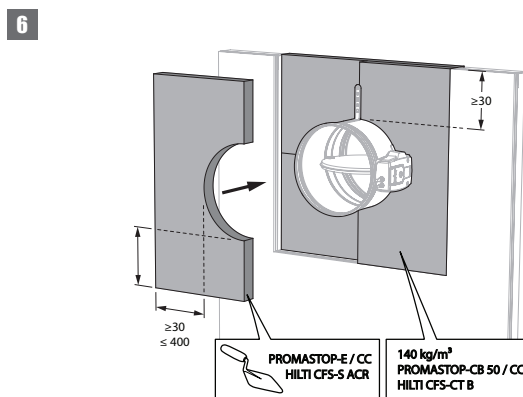

### Installation remote from the wall, sealing and insulation with rigid rock wool boards with coating

The product was tested and approved in:

Range	Wall type	Sealing	Classification	
Ø 100-315 mm	Rigid wall	Aerated concrete ≥ 100 mm	Galvanised duct + stone wool + coating ≥ 140 kg/m <sup>3</sup> 1x60 mm	EI 60 (v <sub>e</sub> i ↔ o) S - (300 Pa)
Ø 100-315 mm	Rigid wall	Aerated concrete ≥ 100 mm	Galvanised duct + stone wool + coating ≥ 140 kg/m <sup>3</sup> 2x50 mm	EI 90 (v <sub>e</sub> i ↔ o) S - (300 Pa)
Ø 100-315 mm	Flexible wall	Metal studs gypsum plasterboard Type F (EN 520) ≥ 100 mm	Galvanised duct + stone wool + coating ≥ 140 kg/m <sup>3</sup> 2x50 mm	EI 90 (v <sub>e</sub> i ↔ o) S - (300 Pa)
Ø 100-315 mm	Flexible wall	Metal studs gypsum plasterboard Type A (EN 520) ≥ 100 mm	Galvanised duct + stone wool + coating ≥ 140 kg/m <sup>3</sup> 1x60 mm	EI 60 (v <sub>e</sub> i ↔ o) S - (300 Pa)

1

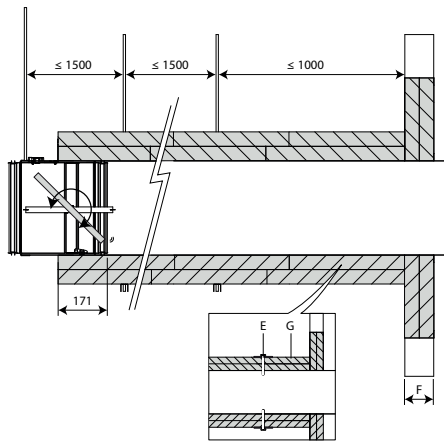

2

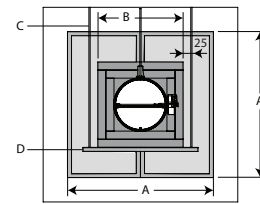

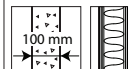
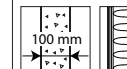
	EI60S	EI90S
A	≤(Øn+600)x (Øn+600)	≤(Øn+600)x (Øn+600)
B	(Ø+120)x(Ø+120)	(Ø+200)x(Ø+200)
C	M8	M10
D	35x35x2 mm	50x50x3 mm
E	9x(Ø5x90 + M6x44)/m <sup>2</sup>	9x(Ø5x120 + M6x44)/m <sup>2</sup>
F	 A (EN520)	 F (EN520)
G	1x60mm Promastop CB60 / 2x50mm Promastop CB-CC50 / Hilti CFS-CT B	2x50 mm Promastop CB50 (CC) / Hilti CFS-CT B

3

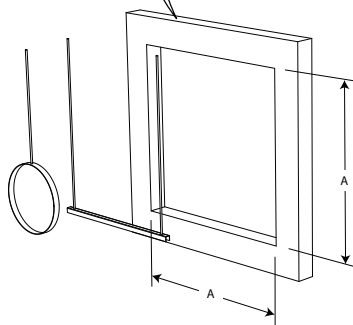
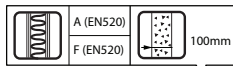

4

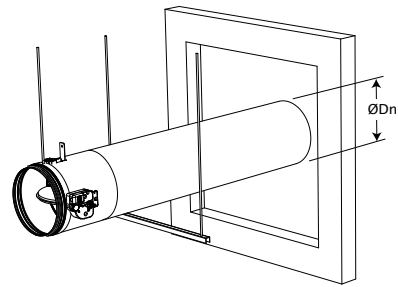

3. An opening with maximal dimensions "A" is made in the wall. For a light partition wall, follow the wall assembly under "Installation in flexible or rigid wall - Sealing with fire resistant rigid panels of mineral wool".

4. The fire damper is mounted remote from the wall at the end of a metal duct. The fire damper is supported by a clamping ring of the same diameter as the damper, held in place by threaded rods "C". The duct is supported every 1500 mm. The suspensions consist of threaded rods "C" and U-shaped steel profiles "D". A free space of maximum 25 mm is left between the threaded rods and the vertical walls of the stone wool casing "B".

5

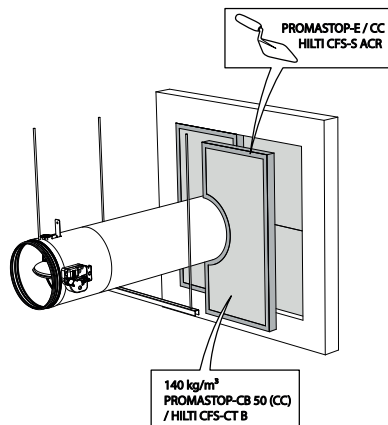

5. The opening around the duct is sealed with stone wool plates type Promastop CB/(CC) / Hilti CFS-CT B ("G"). The edges are sealed and maintained in place with PROMASTOP E / PROMASTOP CC / HILTI CFS-S ACR coating.

6

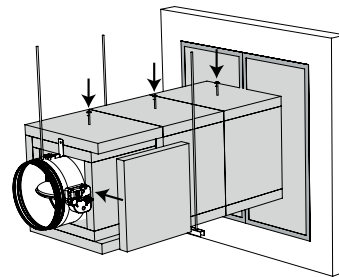

6. The duct is covered over its entire length with stone wool plates "G". To adhere to the duct, the plates are completely coated on one side with fire resistant coating and affixed to the duct with steel screws and washers "E". The damper casing is covered with stone wool plates "G" for 171 mm. A free space should be left around the mechanism to guarantee access. The joints between the plates, between the wall and the plates as well as the screws and washers are filled with coating PROMASTOP E / PROMASTOP CC / HILTI CFS-S ACR.

7

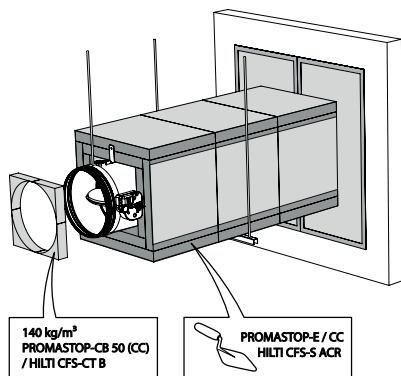

7. An additional stone wool panel type "G", coated with PROMASTOP E / PROMASTOP CC / HILTI CFS-S ACR, is applied in the opening between the damper casing and the stone wool panels.

8

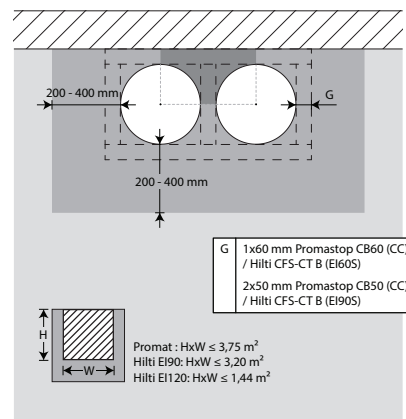

8. The dampers can be installed at a minimum distance from an adjacent wall or from another damper.

9

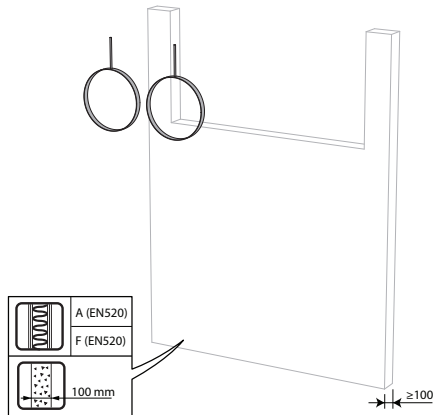

10

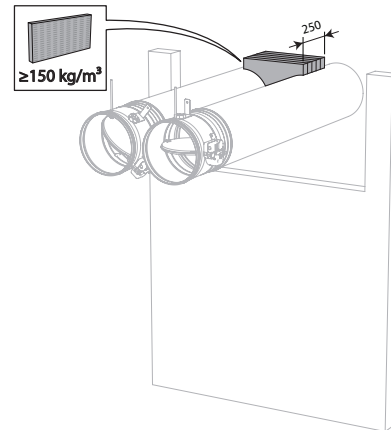

10. Apply rigid stone wool panels ( $150 \text{ kg/m}^3$ ) to a depth of 250 mm (wall thickness + additional at the rear side of the wall) to seal the opening at the side with minimal distances. When the distance between the damper and the wall is greater than 75 mm, the sealing of the opening between the damper and the wall is carried out according to the pre-existing classification.

11

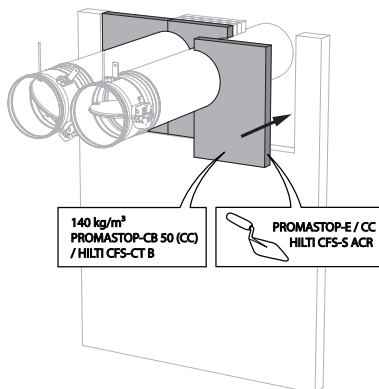

12

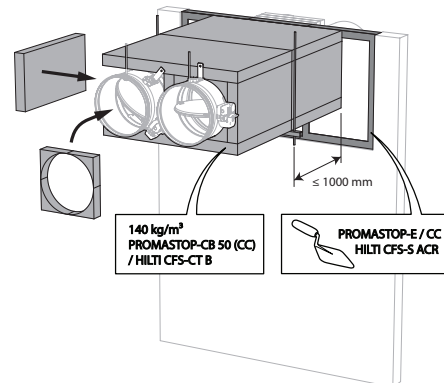

13

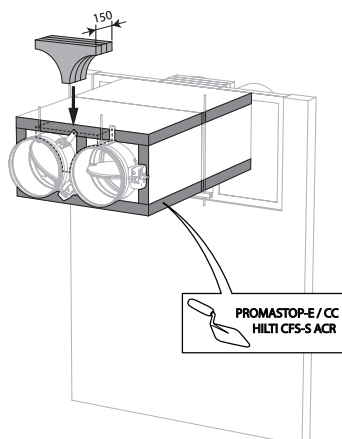

13. Apply rigid stone wool panels ( $150 \text{ kg/m}^3$ ) to a depth of 150 mm to seal the opening at the side with minimal distances.

## Installation remote from the wall, sealing with mortar and insulation with rigid rock wool boards with coating

The product was tested and approved in:

Range	Wall type	Sealing	Classification
Ø 100-315 mm	Rigid wall	Galvanised duct + stone wool + coating ≥ 140 kg/m <sup>3</sup> 2x50 mm + mortar	EI 90 (v <sub>e</sub> i ↔ o) S - (300 Pa)

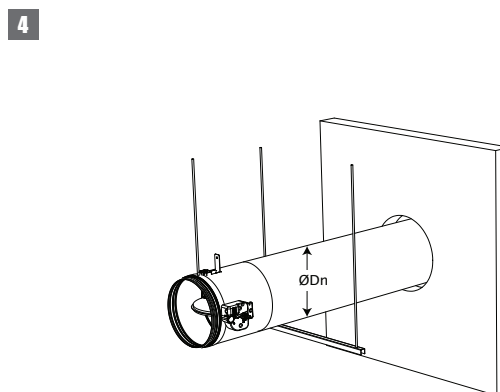
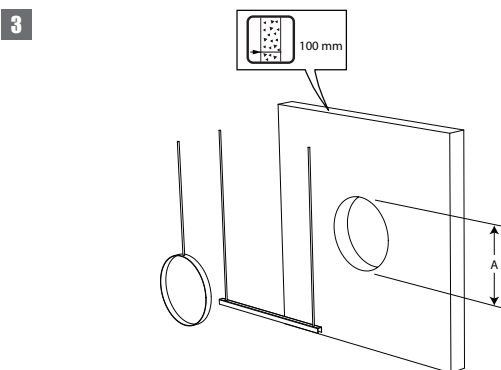
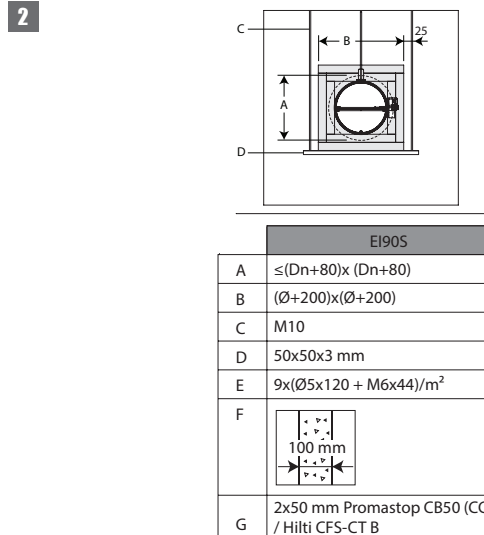
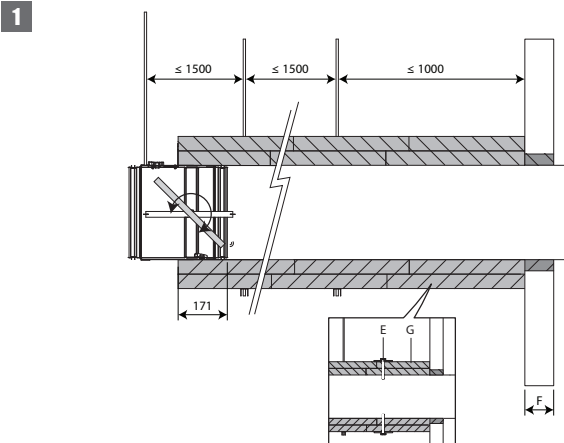

3. An opening with maximal dimensions "A" is made in the wall.

4. The fire damper is mounted remote from the wall at the end of a metal duct. The fire damper is supported by a clamping ring of the same diameter as the damper, held in place by threaded rods "C". The duct is supported every 1500 mm. The suspensions consist of threaded rods "C" and U-shaped steel profiles "D". A free space of maximum 25 mm is left between the threaded rods and the vertical walls of the stone wool casing "B".

5

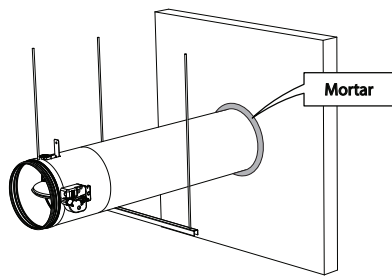

5. The opening around the duct is sealed with standard mortar.

6

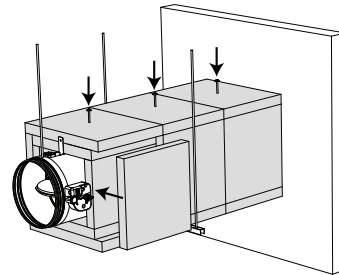

6. The duct is covered over its entire length with stone wool plates "G". To adhere to the duct, the plates are completely coated on one side with fire resistant coating and affixed to the duct with steel screws and washers "E". The damper casing is covered with stone wool plates "G" for 171 mm. A free space should be left around the mechanism to guarantee access. The joints between the plates, between the wall and the plates as well as the screws and washers are filled with coating PROMASTOP E / PROMASTOP CC / HILTI CFS-S ACR.

7

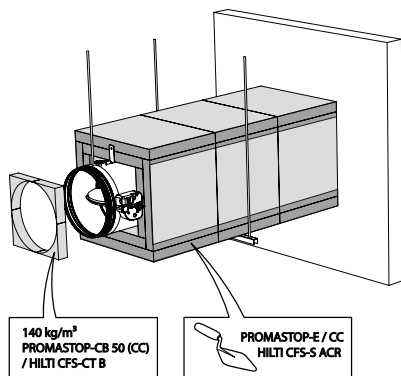

7. An additional stone wool panel type "G", coated with PROMASTOP E / PROMASTOP CC / HILTI CFS-S ACR, is applied in the opening between the damper casing and the stone wool panels.

8

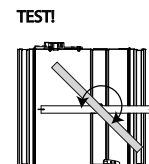



## Installation remote from the wall + GEOFLAM

The product was tested and approved in:

Range	Wall type	Sealing	Classification
Ø 100-315 mm	Rigid wall	Aerated concrete ≥ 100 mm	Galvanised duct + GEOFLAM® F 45 mm + mortar
Ø 100-315 mm	Rigid wall	Aerated concrete ≥ 100 mm	Galvanised duct + GEOFLAM® Light 35 mm + mortar

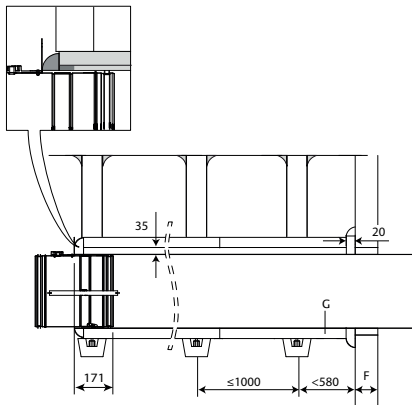
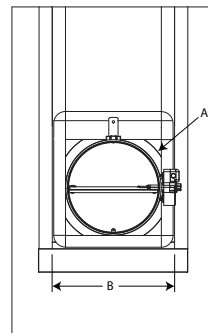
**1**

**2**

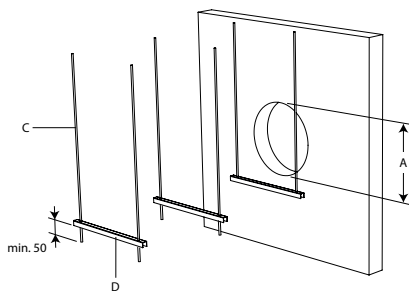
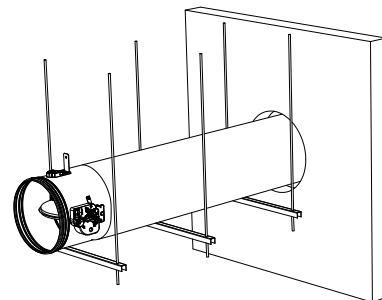
EI90S	
A	≥Dn+80
B	(Dn+125) x(Dn+125)
C	M8
D	25x25x2 mm
E	Lijm, plaaster met vezels
F	
G	Geoflam F 45 mm Geoflam Light 35 mm

**3**

**4**

3. An opening with maximal dimensions "A" is made in the wall.

4. The fire damper is mounted remote from the wall at the end of a metal duct. The duct is supported every 1000 mm. The suspensions consist of threaded rods "C" and U-shaped steel profiles "D". A free space of maximum 25 mm is left between the threaded rods and the vertical walls of the casing "B".

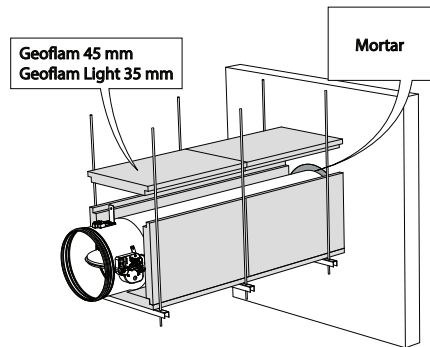
5



5. The opening around the duct is sealed with standard mortar. The duct is covered with 45 mm thick GEOFLAM F plates or 35 mm thick GEOFLAM Light plates "G". The plates adhere to each other with glue and fibrous plaster "E". The damper casing is also covered on a length of 171 mm.

6

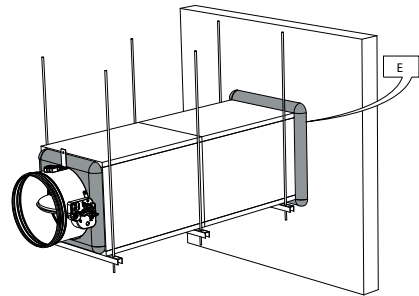

6. The GEOFLAM F / GEOFLAM Light plates stop at a distance of 20 mm from the wall. The free space is filled with fibrous plaster. The same filling is applied to seal off the connection between the GEOFLAM F plates and the damper casing.

7

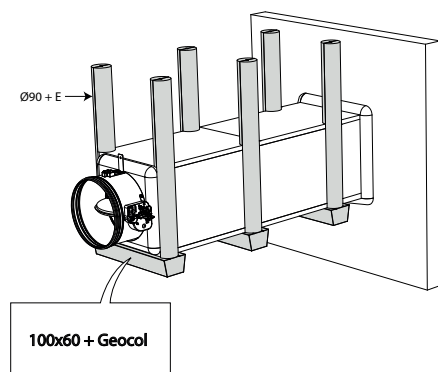

7. The threaded rods are covered with U-shaped plates of GEOFLAM (Ø 90 mm) and affixed with glue and fibrous plaster. The profiles are covered with U-shaped shells GEOFLAM 100 x 60 mm, which are affixed to the underside of the shaft with GEOCOL (GEOSTAFF) cement plaster.

8

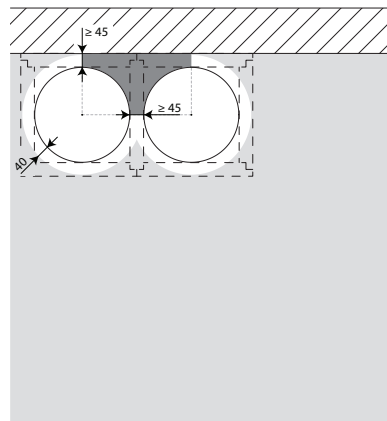

8. The dampers can be installed at a minimum distance from an adjacent wall or from another damper.

9

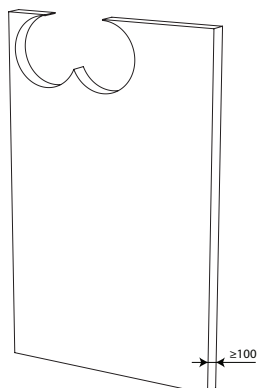

10

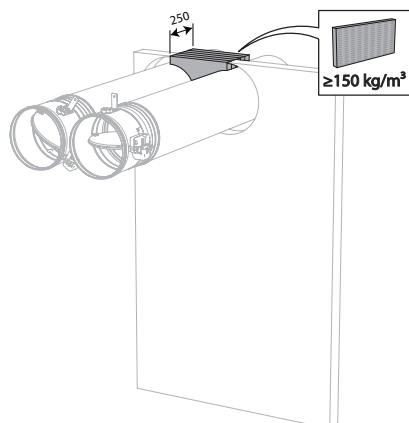

10. Apply rigid stone wool panels ( $150 \text{ kg/m}^3$ ) to a depth of 250 mm (wall thickness + additional at the rear side of the wall) to seal the opening at the side with minimal distances.

11

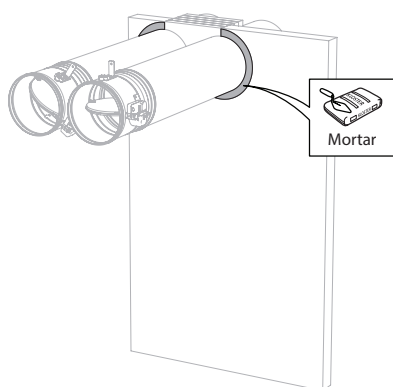

12

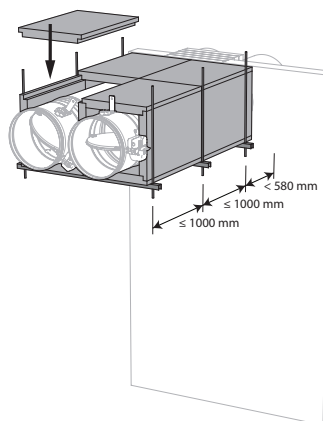

13

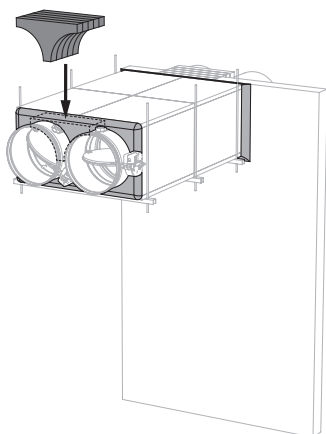

14

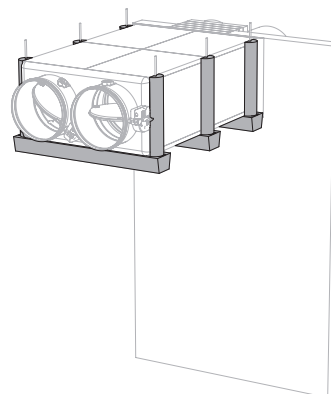

13. Apply rigid stone wool panels ( $150 \text{ kg/m}^3$ ) to a depth of 150 mm to seal the opening at the side with minimal distances.

## Inspection of the damper

1

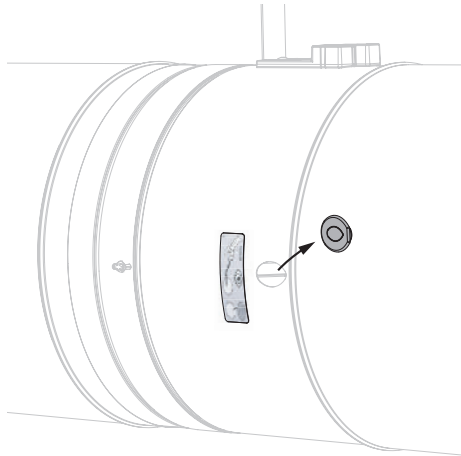

1. Remove the air-tight plug from the damper.

2

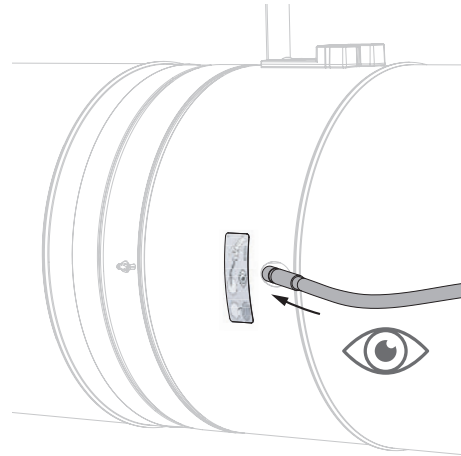

2. Insert the camera of the endoscope (for example Inspecam Rf-t) through the opening and inspect the inside of the damper.

3

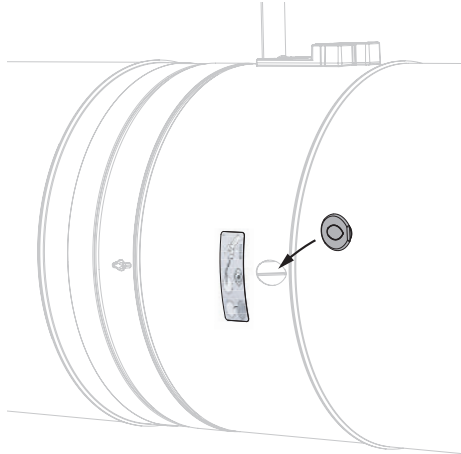

3. After inspection, replace the air-tight plug thoroughly on the damper opening. The position is crucial in order to maintain the air-tightness of the fire damper.

## Maintenance

- No specific maintenance required.
- Schedule at least 2 visual checks each year.
- Remove dust and all other particles before use.
- Follow local maintenance regulations (i.e. BS9999 Annex V; NF S 61-933) and EN13306.
- Read the maintenance instructions on our website:  
[https://www.rft.eu/assets//PIM/DOCUMENTS/BROCHURE%20KITS/BRO\\_K139\\_MAINTENANCE\\_C.pdf](https://www.rft.eu/assets//PIM/DOCUMENTS/BROCHURE%20KITS/BRO_K139_MAINTENANCE_C.pdf)
- Use the damper at up to 95% humidity, non-condensing.
- The fire damper can be cleaned with a dry or slightly damp cloth. It is forbidden to use abrasive cleaners or mechanical cleaning techniques (brush).

## Operation and mechanisms



### MFUS(P) Mechanism with fusible link

The operating mechanism MFUS(P) automatically unlocks the blade when the temperature in the duct exceeds 72°C. The damper can also be unlocked and reset manually.

1. unlocking button
2. resetting handle
3. cable entrance

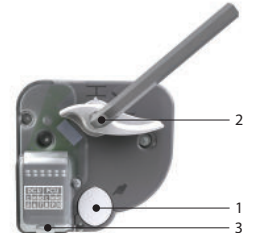

### Options - at the time of order

**FDCU** Limit switch 'open/closed'

#### Unlocking

- **manual unlocking:** press the unlocking button (1).
- **automatic unlocking:** the fusible link melts when the temperature reaches 72°C in the duct.
- **remote unlocking:** n/a

#### Resetting

- **manual resetting:** turn the resetting handle (2) 90° clockwise (or use a 10 mm hex key).
- **motorised resetting:** n/a

#### Caution:

- ⚠ The mechanism may never be tested on its own, without being attached to the damper. Such a test might damage the mechanism or the operator might be injured.



## ONE Spring return actuator for remote control

The spring-return actuator ONE is designed to easily operate Rf-t fire dampers of all sizes, automatically or remotely. Six models are available, 24 or 230 volt, with FDCU or FDCB position switches; and optionally with plug (ST).

1. unlocking button
2. blade position indicator
3. LED
4. battery compartment to reset motor

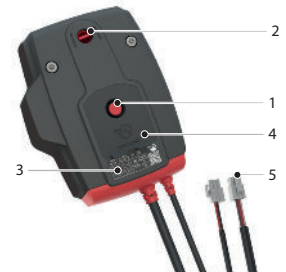

### Unlocking

- **manual unlocking:** shortly press the unlocking button (1) once.
- **automatic unlocking:** the fusible link reacts as soon as the temperature in the duct reaches 72°C.
- **remote unlocking:** by interrupting the power supply.

### Resetting

- **manual resetting:** open the battery compartment (4) and press a 9V battery against the contact springs. Hold this position until the LED (3) emits a continuous light. Check whether the indicator (2) shows that the damper blade is in the open position. Remove the battery, the LED fades away. Close the battery compartment.
- **motorised resetting:** switch off the power supply for at least 5 sec. Power the actuator (respect the prescribed voltage) for at least 75 sec. The resetting stops automatically when the end of range is reached (damper open).

### Caution:

- ▲ If the LED (3) flickers fast (3x/sec.), the battery is discharged: use a new battery.
- ▲ If the LED (3) flickers slowly (1x/sec), the resetting is in progress.
- ▲ If the LED (3) is continuously on, the resetting is complete and the motor is powered.
- ▲ If the actuator detects voltage on the power cable, a brief contact of the battery is enough to start the resetting process.
- ▲ The power supply of this actuator cannot be individually replaced. If the cable is damaged, the whole unit must be discarded and replaced.
- ▲ The housing of the mechanism contains a temperature sensor. When the temperature in the housing exceeds 72°C, the mechanism unlocks. The LED flashes twice per second. When the temperature drops below 72°C, the mechanism can only be reset in a motorised manner after a manual reset (with a battery).
- ▲ The end of range switches need 1 second after operation to adopt a stable position.
- ▲ Make sure the thermal trigger device is present in the actuator. The actuator might not function properly if this is not the case.

	prod. < 1/7/2015				prod. ≥ 1/7/2015			
	CR60(1s) CR120	CU-LT CU-LT-1s	CR2≤400 CU2≤1200	CR2>400 CU2>1200	CR60(1s) CR120(1s)	CU-LT CU-LT-1s	CR2≤400 CU2≤1200	CR2>400 CU2>1200
Kit ONE	●	●	●		●	●	●	●



## ONE-X Spring return actuator with integrated communication module.

The ONE-X is a spring return actuator with integrated communication module designed to simply operate Rf-t fire dampers of all sizes, automatically or remotely. The ONE-X is available in two versions: 24 V and 230 V.

1. unlocking button
2. blade position indicator
3. LED red: status
4. battery compartment
5. LED blue: communication
6. LED orange: error message
7. supply
8. bus cable

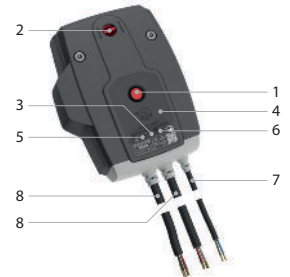

### Unlocking

- **manual unlocking:** shortly press the unlocking button (1) once.
- **automatic unlocking:** the fusible link reacts as soon as the temperature in the duct reaches 72°C.
- **remote unlocking:** via ZENiX controller

### Resetting

- **manual resetting:** Open the battery compartment (4) and press a 9V battery against the contact springs. Hold this position until the red LED (3) emits a continuous light. Control whether the indicator (2) indicates that the damper blade is open. Remove the battery. Close the battery compartment.
- **motorised resetting:** via ZENiX controller. By applying voltage during first use.

### Caution:

- ▲ If the ONE-X detects voltage on the power cable, a brief contact of the battery is enough to start the resetting process, provided the ZENiX controller has sent the damper to open position or the ONE-X is being operated for the first time.
- ▲ The power supply of this actuator cannot be individually replaced. If the cable is damaged, the whole unit must be discarded and replaced.
- ▲ The housing of the mechanism contains a temperature sensor. When the temperature in the housing exceeds 72°C, the mechanism unlocks. The LED flashes twice per second. When the temperature drops below 72°C, the mechanism can only be reset in a motorised manner after a manual reset (with a battery).
- ▲ The end of range switches need 1 second after operation to adopt a stable position.

### Safety regulations:

- ▲ Do not use the ONE-X for any application other than the specified applications, in particular not in aircraft or other airborne vehicles.
- ▲ The company that purchases and/or installs the ONE-X is fully responsible for the correct operation of the entire system. Only authorised specialists may perform the installation. All rules and regulations, including statutory regulations, must be observed during installation.
- ▲ This device contains electrical or electronic components and must not be disposed of as household waste. All locally applicable regulations and requirements must be strictly observed.



## BFL(T) Remotely controlled spring return actuator

The spring return actuator BFL(T) is especially designed to operate fire dampers remotely. The BFL(T) variant is intended for fire dampers with smaller dimensions (CR60, CR120, CR2 with  $\varnothing \leq 400$  mm, CRS60 with  $\varnothing \leq 315$  mm, CU2 / CU2-15 / CU4 with B+H  $\leq 1200$  mm or for CU-LT and CU-LT-1s). For Markage FD with H = 200 mm or H = 2200 mm (in combination with BFT motor).

1. locking button
2. plug (ST)
3. access for manual resetting
4. thermo-electric tripping device (T)



### Options - at the time of order

**SN2 BFL/BFN** Auxiliary limit switch 'open/closed'

### Unlocking

- **manual unlocking:** place the locking button on "unlock". (In case of BFLT: the damper can alternatively be unlocked by pushing the "test" button on the thermo-electric fuse)
- **automatic unlocking:** the thermo-electric fuse reacts as soon as the temperature reaches 72°C (type BFLT).
- **remote unlocking:** by interrupting the power supply.

#### Caution:

- ⚠ The thermo-electric fuse will not move the damper into its safety position (when the temperature reaches 72°C) if the motor is not powered.

### Resetting

- **manual resetting:** turn the enclosed handle anti-clockwise. To block the motor, place the locking button on "lock"
- **motorised resetting:** switch off the power supply for at least 10 seconds. Supply the actuator (respect the prescribed voltage) for at least 75 seconds. The resetting stops automatically when the end of range is reached (damper open) - it takes about 60 seconds to reset the damper - or when the power supply is interrupted.

#### Caution:

- ⚠ Do not use a drill or powered screwdriver.
- ⚠ Stop as soon as the motor is completely rearmed (end of range).

	prod. < 1/7/2015				prod. ≥ 1/7/2015			
	CR60(1s) CR120	CU-LT CU-LT-1s	CR2≤400 CU2≤1200	CR2>400 CU2>1200	CR60(1s) CR120 (1s)	CU-LT CU-LT-1s	CR2≤400 CU2≤1200	CR2>400 CU2>1200
Kit BFL					●	●	●	
Kit BFN	●	●	●					●
Kit BF				●				



## Electrical connection

### MFUS(P)

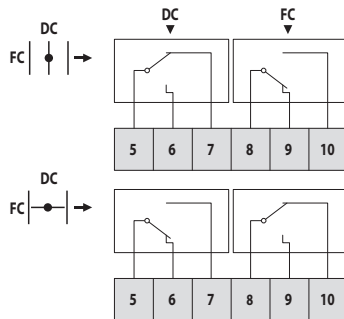

DC : Switch open position fire damper  
FC : Switch closed position fire damper

### ONE

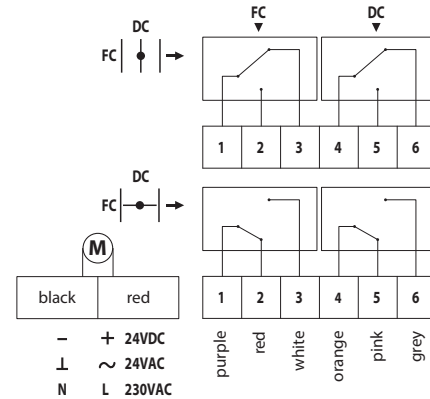

DC : Switch open position fire damper  
FC : Switch closed position fire damper

### ONE-X

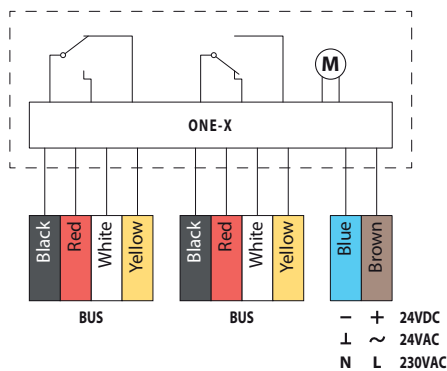

### BFLT(T)

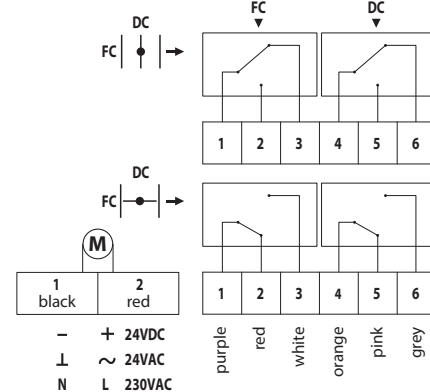

DC : Switch open position fire damper  
FC : Switch closed position fire damper

MEC	Nominal voltage motor	Nominal voltage magnet	Power consumption (stand-by)	Power consumption (operating)	Standard switches	Resetting time motor
MFUS	N/A	N/A	N/A	N/A	1mA...1A, DC 5V...AC 48V	N/A
ONET 24 FDCU	24 V AC/DC (-10/+20%)	N/A	0,28 W	4,2W	1mA...1A 60V	< 75 s (cabled) / <85 s (battery)
ONET 24 FDCU ST	24 V AC/DC (-10/+20%)	N/A	0,28 W	4,2W	1mA...1A 60V	< 75 s (cabled) / <85 s (battery)
ONET 230 FDCU	230 V AC (-15/+15%)	N/A	0,57 W	4,2W	1mA...100mA 230V	< 75 s (cabled) / <85 s (battery)
ONET 230 FDCU ST	230 V AC (-15/+15%)	N/A	0,57 W	4,2W	1mA...100mA 230V	< 75 s (cabled) / <85 s (battery)
ONET 24 FDCB	24 V AC/DC (-10/+20%)	N/A	0,28 W	4,2W	1mA...1A 60V	< 75 s (cabled) / <85 s (battery)
ONET 230 FDCB	230 V AC (-15/+15%)	N/A	0,57 W	4,2W	1mA...1A 60V	< 75 s (cabled) / <85 s (battery)
ONE-X 24	24 V AC/DC (-10/+20%)	N/A	0,28 W	4,2W		< 75 s (cabled) / <85 s (battery)
ONE-X 230	230 V AC (-15/+15%)	N/A	0,57 W	4,2W		< 75 s (cabled) / <85 s (battery)
BFL24	24 V AC/DC	N/A	0,7 W	2,5 W	1mA...3A, AC 250V	< 60 s
BFL24-ST	24 V AC/DC	N/A	0,7 W	2,5 W	1mA...3A, AC 250V	< 60 s
BFL230	230 V AC	N/A	1,1 W	3,5 W	1mA...3A, AC 250V	< 60 s
BFLT24	24 V AC/DC	N/A	0,8 W	2,5 W	1mA...3A, AC 250V	< 60 s
BFLT24-ST	24 V AC/DC	N/A	0,8 W	2,5 W	1mA...3A, AC 250V	< 60 s
BFLT230	230 V AC	N/A	1,4 W	4 W	1mA...3A, AC 250V	< 60 s
BFLT230-ST	230 V AC	N/A	1,4 W	4 W	1mA...3A, AC 250V	< 60 s

MEC	Running time spring	Noise level motor	Noise level spring	Cable supply / control	Cable auxiliary switch	Protection class
MFUS	1 s	N/A	N/A			IP 42
ONET 24 FDCU	< 30 s	< 64 dB (A)	< 67 dB (A)	1 m, 2 x 0.75 mm <sup>2</sup> (halogen-free)	1 m, 6 x 0.75 mm <sup>2</sup> (halogen-free)	IP 54
ONET 24 FDCU ST	< 30 s	< 64 dB (A)	< 67 dB (A)	1 m, 2 x 0.75 mm <sup>2</sup> (halogen-free)	1 m, 6 x 0.75 mm <sup>2</sup> (halogen-free)	IP 54
ONET 230 FDCU	< 30 s	< 64 dB (A)	< 67 dB (A)	1 m, 2 x 0.75 mm <sup>2</sup> (halogen-free)	1 m, 6 x 0.75 mm <sup>2</sup> (halogen-free)	IP 54
ONET 230 FDCU ST	< 30 s	< 64 dB (A)	< 67 dB (A)	1 m, 2 x 0.75 mm <sup>2</sup> (halogen-free)	1 m, 6 x 0.75 mm <sup>2</sup> (halogen-free)	IP 54
ONET 24 FDCB	< 30 s	< 64 dB (A)	< 67 dB (A)	1 m, 2 x 0.75 mm <sup>2</sup> (halogen-free)	(2x) 1 m, 6 x 0,75 mm <sup>2</sup> (halogen-free)	IP 54
ONET 230 FDCB	< 30 s	< 64 dB (A)	< 67 dB (A)	1 m, 2 x 0.75 mm <sup>2</sup> (halogen-free)	(2x) 1 m, 6 x 0,75 mm <sup>2</sup> (halogen-free)	IP 54
ONE-X 24	< 30 s	< 64 dB (A)	< 67 dB (A)	1 m, 2 x 0.75 mm <sup>2</sup> (halogen-free)	bus cable: (2x) 1 m, 4 x 0,75 mm <sup>2</sup> (halogen-free)	IP 54
ONE-X 230	< 30 s	< 64 dB (A)	< 67 dB (A)	1 m, 2 x 0.75 mm <sup>2</sup> (halogen-free)	bus cable: (2x) 1 m, 4 x 0,75 mm <sup>2</sup> (halogen-free)	IP 54
BFL24	20 s	< 43 dB (A)	< 62 dB (A)	1 m, 2 x 0.75 mm <sup>2</sup> (halogen-free)	1 m, 6 x 0.75 mm <sup>2</sup> (halogen-free)	IP 54
BFL24-ST	20 s	< 43 dB (A)	< 62 dB (A)	1 m, 2 x 0.75 mm <sup>2</sup> (halogen-free)	1 m, 6 x 0.75 mm <sup>2</sup> (halogen-free)	IP 54
BFL230	20 s	< 43 dB (A)	< 62 dB (A)	1 m, 2 x 0.75 mm <sup>2</sup> (halogen-free)	1 m, 6 x 0.75 mm <sup>2</sup> (halogen-free)	IP 54
BFLT24	20 s	< 43 dB (A)	< 62 dB (A)	1 m, 2 x 0.75 mm <sup>2</sup> (halogen-free)	1 m, 6 x 0.75 mm <sup>2</sup> (halogen-free)	IP 54
BFLT24-ST	20 s	< 43 dB (A)	< 62 dB (A)	1 m, 2 x 0.75 mm <sup>2</sup> (halogen-free)	1 m, 6 x 0.75 mm <sup>2</sup> (halogen-free)	IP 54
BFLT230	20 s	< 43 dB (A)	< 62 dB (A)	1 m, 2 x 0.75 mm <sup>2</sup> (halogen-free)	1 m, 6 x 0.75 mm <sup>2</sup> (halogen-free)	IP 54
BFLT230-ST	20 s	< 43 dB (A)	< 62 dB (A)	1 m, 2 x 0.75 mm <sup>2</sup> (halogen-free)	1 m, 6 x 0.75 mm <sup>2</sup> (halogen-free)	IP 54

## Weights

## CR60 + MFUS

ØDn [mm]	100	125	150	160	180	200	250	300	315
kg	1,6	1,8	2,0	2,1	2,5	2,6	3,3	4,1	4,2

## CR60 + ONE

ØDn [mm]	100	125	150	160	180	200	250	300	315
kg	2,8	3,0	3,2	3,3	3,7	3,8	4,5	5,3	5,4

## CR60 + BFL

ØDn [mm]	100	125	150	160	180	200	250	300	315
kg	2,3	2,5	2,7	2,8	3,2	3,3	4,0	4,8	4,9

## CR60 + BFLT

ØDn [mm]	100	125	150	160	180	200	250	300	315
kg	2,4	2,6	2,8	2,9	3,3	3,4	4,1	4,9	5,0

## CR60-L500 + MFUS

ØDn [mm]	100	125	150	160	180	200	250	300	315
kg	1,9	2,3	2,6	2,7	3,2	3,4	4,2	5,3	5,4

## CR60-L500 + ONE

ØDn [mm]	100	125	150	160	180	200	250	300	315
kg	3,1	3,5	3,8	3,9	4,4	4,6	5,4	6,5	6,6

## CR60-L500 + BFL

ØDn [mm]	100	125	150	160	180	200	250	300	315
kg	2,6	3,0	3,3	3,4	3,9	4,1	4,9	6,0	6,1

## CR60-L500 + BFLT

ØDn [mm]	100	125	150	160	180	200	250	300	315
kg	2,7	3,1	3,4	3,5	4,0	4,2	5,0	6,1	6,2

## CR60-1S + MFUS

ØDn [mm]	100	125	160	200	250	315
kg	6,0	6,7	8,5	9,7	11,2	12,4

## CR60-1S + ONE

ØDn [mm]	100	125	160	200	250	315
kg	7,2	7,9	9,7	10,9	12,4	13,6

## CR60-1S + BFL

ØDn [mm]	100	125	160	200	250	315
kg	6,7	7,4	9,2	10,4	11,9	13,1

## Selection data

### CR60-1S + BFLT

ØDn [mm]	100	125	160	200	250	315				
kg	6,8	7,5	9,3	10,5	12,0	13,2				

### CR60-1S-L500 + MFUS

ØDn [mm]	100	125	160	200	250	315				
kg	6,3	7,2	9,1	10,5	12,1	13,6				

### CR60-1S-L500 + ONE

ØDn [mm]	100	125	160	200	250	315				
kg	7,5	8,4	10,3	11,7	13,3	14,8				

### CR60-1S-L500 + BFL

ØDn [mm]	100	125	160	200	250	315				
kg	7,0	7,9	9,8	11,2	12,8	14,3				

### CR60-1S-L500 + BFLT

ØDn [mm]	100	125	160	200	250	315				
kg	7,1	8,0	9,9	11,3	12,9	14,4				

## Selection data

$$\Delta p \text{ [Pa]} = \zeta^* v^2 * 0,6$$

ØDn [mm]	100	125	150	160	180	200	250	300	315	
ζ [-]	0,87	0,73	0,6	0,56	0,48	0,42	0,29	0,19	0,18	

## Example

### Data

Dn = 250 mm, v = 5 m/s

### Calculation

$$\Delta p = 0,29 * (5 \text{ m/s})^2 * 0,6 = 4,35 \text{ Pa}$$

### CR60 - A-weighted sound power level L<sub>wa</sub> in the room

	100	125	150	160	180	200	250	300	315		
S <sub>n</sub> [m <sup>2</sup> ]	0,0047	0,0082	0,0128	0,0148	0,0195	0,0248	0,0407	0,0605	0,0672		
S <sub>n</sub> [%]	59,82	67,14	72,22	73,84	76,57	78,79	82,85	85,61	86,27		
Q [m <sup>3</sup> /h]	234	356	503	568	711	868	1327	1878	2060		
Δp [Pa]	36,15	28,59	22,34	20,73	17,27	14,78	9,69	6,33	5,69		<b>45 dB</b>
Q [m <sup>3</sup> /h]	180	275	388	438	548	670	1024	1448	1589		<b>40 dB</b>
Δp [Pa]	21,51	17,01	13,29	12,34	10,27	8,79	5,77	3,77	3,39		<b>35 dB</b>
Q [m <sup>3</sup> /h]	139	212	299	338	423	517	790	1117	1226		<b>30 dB</b>
Δp [Pa]	12,8	10,12	7,91	7,34	6,11	5,23	3,43	2,24	2,01		<b>25 dB</b>
Q [m <sup>3</sup> /h]	107	164	231	261	326	398	609	862	946		<b>20 dB</b>
Δp [Pa]	7,62	6,02	4,71	4,37	3,64	3,11	2,04	1,33	1,2		<b>15 dB</b>
Q [m <sup>3</sup> /h]	83	126	178	201	252	307	470	665	729		<b>10 dB</b>
Δp [Pa]	4,53	3,58	2,8	2,6	2,16	1,85	1,21	0,79	0,71		<b>5 dB</b>

Every air flow lower than the above mentioned maximum value, will meet the listed A-weighted sound power level for the respective dimension. More information on sound power can be found in the product information on our website (documents).

**CR60-L500 - A-weighted sound power level Lwa in the room**

	100	125	150	160	180	200	250	300	315		
Sn [m <sup>2</sup> ]	0,0047	0,0082	0,0128	0,0148	0,0195	0,0248	0,0407	0,0605	0,0672		
Sn [%]	59,82	67,14	72,22	73,84	76,57	78,79	82,85	85,61	86,27		
Q [m <sup>3</sup> /h]	234	356	503	568	711	868	1327	1878	2060		
Δp [Pa]	36,15	28,59	22,34	20,73	17,27	14,78	9,69	6,33	5,69		<b>45 dB</b>
Q [m <sup>3</sup> /h]	180	275	388	438	548	670	1024	1448	1589		
Δp [Pa]	21,51	17,01	13,29	12,34	10,27	8,79	5,77	3,77	3,39		<b>40 dB</b>
Q [m <sup>3</sup> /h]	139	212	299	338	423	517	790	1117	1226		
Δp [Pa]	12,8	10,12	7,91	7,34	6,11	5,23	3,43	2,24	2,01		<b>35 dB</b>
Q [m <sup>3</sup> /h]	107	164	231	261	326	398	609	862	946		
Δp [Pa]	7,62	6,02	4,71	4,37	3,64	3,11	2,04	1,33	1,2		<b>30 dB</b>
Q [m <sup>3</sup> /h]	83	126	178	201	252	307	470	665	729		
Δp [Pa]	4,53	3,58	2,8	2,6	2,16	1,85	1,21	0,79	0,71		<b>25 dB</b>

Every air flow lower than the above mentioned maximum value, will meet the listed A-weighted sound power level for the respective dimension. More information on sound power can be found in the product information on our website (documents).

**CR60-1S - A-weighted sound power level Lwa in the room**

	100	125	160	200	250	315					
Sn [m <sup>2</sup> ]	0,0047	0,0082	0,0148	0,0248	0,0407	0,0672					
Sn [%]	59,82	67,14	73,84	78,79	82,85	86,27					
Q [m <sup>3</sup> /h]	234	356	568	868	1327	2060					
Δp [Pa]	36,15	28,59	20,73	14,78	9,69	5,69					<b>45 dB</b>
Q [m <sup>3</sup> /h]	180	275	438	670	1024	1589					
Δp [Pa]	21,51	17,01	12,34	8,79	5,77	3,39					<b>40 dB</b>
Q [m <sup>3</sup> /h]	139	212	338	517	790	1226					
Δp [Pa]	12,8	10,12	7,34	5,23	3,43	2,01					<b>35 dB</b>
Q [m <sup>3</sup> /h]	107	164	261	398	609	946					
Δp [Pa]	7,62	6,02	4,37	3,11	2,04	1,2					<b>30 dB</b>
Q [m <sup>3</sup> /h]	83	126	201	307	470	729					
Δp [Pa]	4,53	3,58	2,6	1,85	1,21	0,71					<b>25 dB</b>

Every air flow lower than the above mentioned maximum value, will meet the listed A-weighted sound power level for the respective dimension. More information on sound power can be found in the product information on our website (documents).

## CR60-1S-L500 - A-weighted sound power level L<sub>wa</sub> in the room

	100	125	160	200	250	315					
Sn [m <sup>2</sup> ]	0,0047	0,0082	0,0148	0,0248	0,0407	0,0672					
Sn [%]	59,82	67,14	73,84	78,79	82,85	86,27					
Q [m <sup>3</sup> /h]	234	356	568	868	1327	2060					<b>45 dB</b>
Δp [Pa]	36,15	28,59	20,73	14,78	9,69	5,69					
Q [m <sup>3</sup> /h]	180	275	438	670	1024	1589					<b>40 dB</b>
Δp [Pa]	21,51	17,01	12,34	8,79	5,77	3,39					
Q [m <sup>3</sup> /h]	139	212	338	517	790	1226					<b>35 dB</b>
Δp [Pa]	12,8	10,12	7,34	5,23	3,43	2,01					
Q [m <sup>3</sup> /h]	107	164	261	398	609	946					<b>30 dB</b>
Δp [Pa]	7,62	6,02	4,37	3,11	2,04	1,2					
Q [m <sup>3</sup> /h]	83	126	201	307	470	729					<b>25 dB</b>
Δp [Pa]	4,53	3,58	2,6	1,85	1,21	0,71					

Every air flow lower than the above mentioned maximum value, will meet the listed A-weighted sound power level for the respective dimension. More information on sound power can be found in the product information on our website (documents).

## Sample order

CR60 200 MFUS FDCU

1

2

3

4

1. product
2. diameter
3. mechanism type
4. option: unipolar end of range switch

## Approvals and certificates

All our dampers are submitted to a number of tests by official test institutes. Reports of these tests form the basis for the approvals of our dampers.



BCCA-0749-CPR-BC1-606-0464-15650.02-2517



18.16



SC0648-15



26815



W-336769-20-Zd



2822-UKCA-CPR-0055

The NF-label guarantees: conformity with the standard NF S 61-937 Parts 1 and 5: "Systèmes de Sécurité Incendie Dispositifs Actionnés de Sécurité"; conformity with the national decree of March 22, 2004, changed on 14 March 2011 for the classification of fire resistance; the values of the characteristics mentioned in this document. Organisme Certificateur: AFNOR Certification, 11 Rue Francis de Pressensé, F93571 La Plaine Saint-Denis Cedex; Website: <http://www.afnor.org> <http://www.marque-nf.com>; Phone: +33 (0)1.41.62.80.00, Fax: +33 (0)1.49.17.90.00, Email: [certification@afnor.org](mailto:certification@afnor.org)